

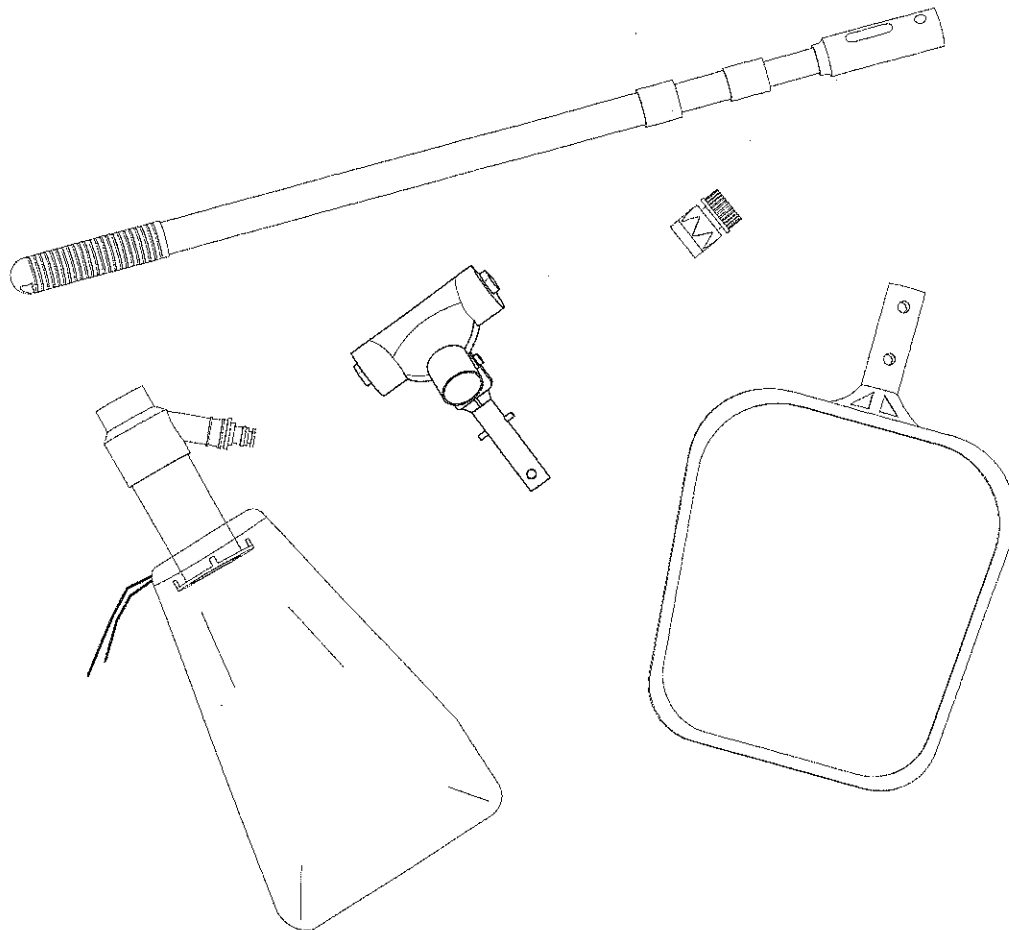

SKU# 230020

POOL MAINTENANCE KIT

INSTRUCTION MANUAL



THANK YOU!

Thank you for purchasing this product. We work around the clock and around the globe to ensure that our products maintain the highest possible quality. Please read the warranty information at the back of these assembly instructions for further details.

SAFETY INFORMATION

Please read this entire manual before attempting to assemble, operate, or install the product.

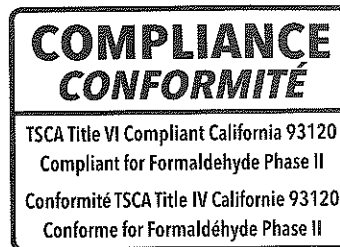
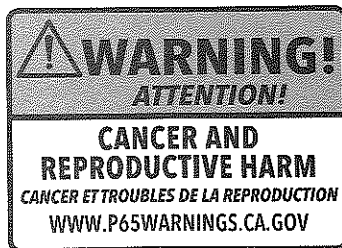

PARTS LIST & DIAGRAMS

(NOT TO SCALE)

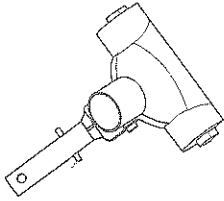
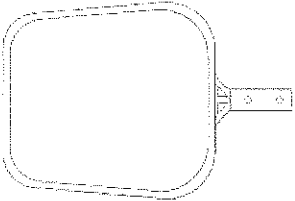
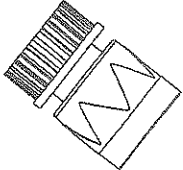
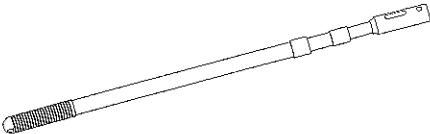
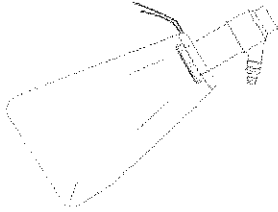
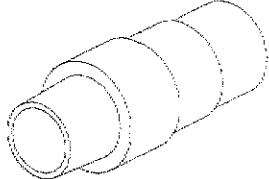
 <p>1. Base Vacuum Head</p>	 <p>2. Hand Skimmer Net</p>	 <p>3. 5/8" Garden Hose Connector</p>
 <p>4. Telescopic Pole</p>	 <p>5. Venturi Vacuum with Bag</p>	 <p>6. 1.25" Vacuum Hose Adaptor</p>

#	Part Description	QTY>	MFG No.	BB No.
1	Base Vacuum Head	1	JV02BU01	230020
2	Hand Skimmer Net	1	LS1310PE	230020
3	5/8" Garden Hose Connector	1	SP07	1004
4	Telescopic Pole	1	TP3	230020
5	Venturi Vacuum with Bag	1	JV02BU03	230020
6	1.25" Vacuum Hose Adaptor	1	90587	230020

OPERATION INSTRUCTIONS

Cleaning with the Hand Skimmer

1. Extend the telescopic pole to its longest length.
2. Attach the hand skimmer to the open end of the telescopic pole.
3. Scoop out leaves or any debris in the pool.

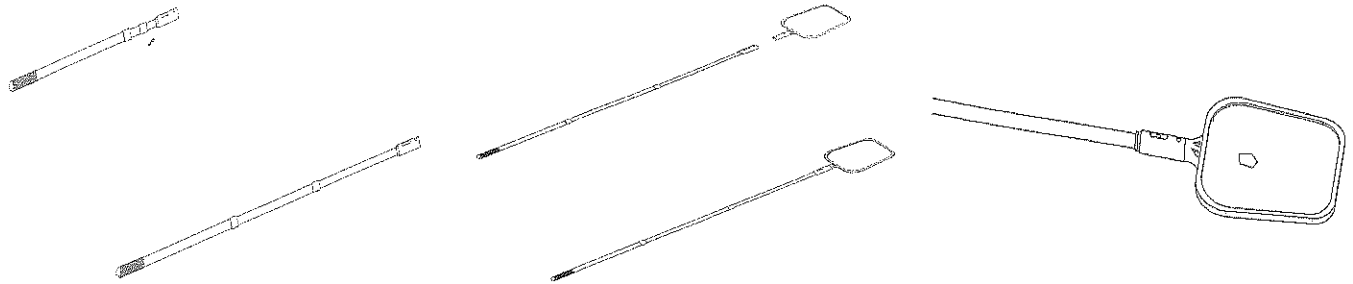

Vacuumping with a 5/8" Garden Hose (Not Included)

1. Extend the Telescopic Pole to its fullest length.
2. Attach the Base Vacuum Head to the open end of the Telescopic Pole.

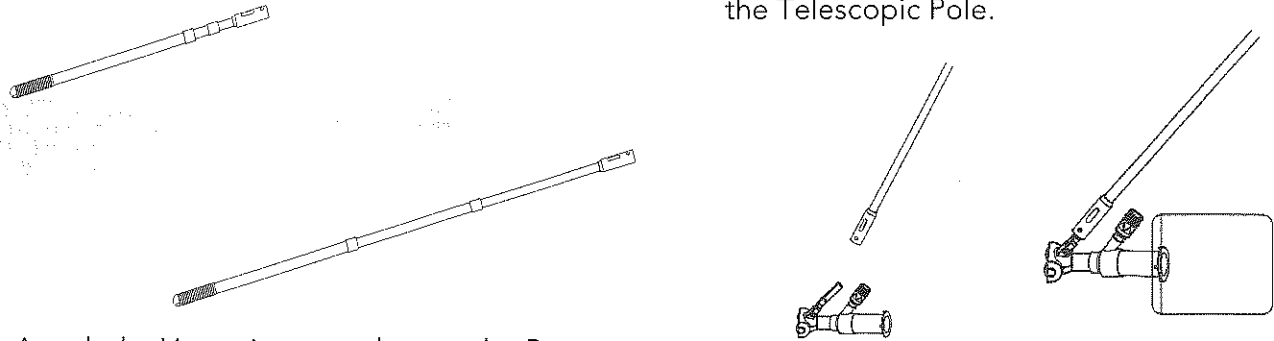

3. Attach the Venturi vacuum bag to the Base Vacuum Head. Then tighten the draw string and tie a knot to secure it in place.
NOTE: Ensure the debris bag is securely tied to the Venturi Vacuum.

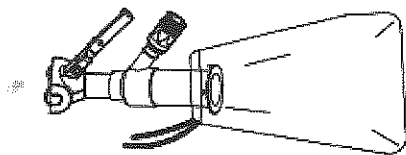

4. Hand tighten a 5/8" Garden Hose to the Vacuum Head.

5. Place the Vacuum under water.

OPERATION INSTRUCTIONS

6. Turn on the water supply. This will cause a venturi suction at the vacuum head. Debris is collected in the vacuum bag.
7. Carefully, and slowly push the Vacuum Head across the pool floor to remove debris. Do not press hard on the liner as this may cause damage.
8. When done or when the bag is full:
 - a) Slowly move the vacuum head to the side wall of the pool, turn the vacuum head upside-down, shut off the water, and remove the vacuum head from the pool.
 - b) Remove the vacuum bag and discard all of the debris, flip the bag inside-out, and rinse with running water.
9. Repeat the above steps until the pool has been cleaned thoroughly.

Vacuuming with Base Vacuum Head

1. Start with the Base Vacuum Head and attach it to the telescopic pole as shown below.
2. Attach a 1.25" Vacuum Hose (Not Included) to the Base Vacuum Head.

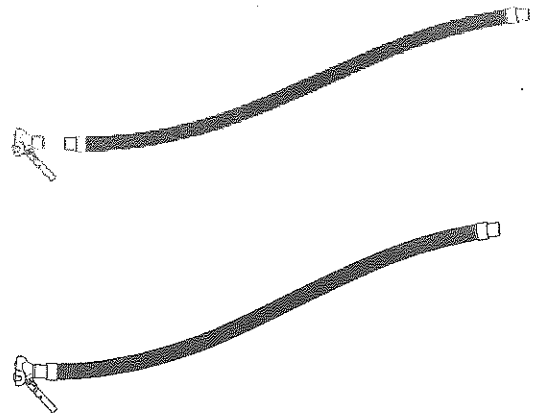
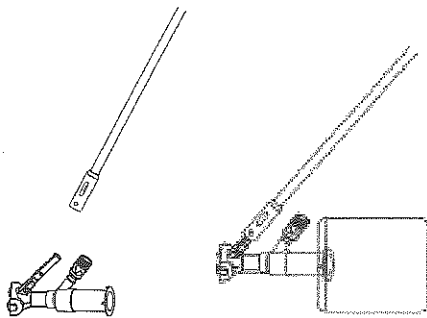

3. Attach the Vacuum Hose Adapter (pictured below) to the open end of the 1.25" Vacuum Hose.

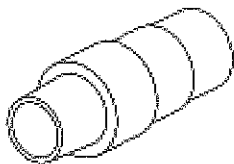

OPERATION INSTRUCTIONS (CONTINUED)

4. Remove the anti-entrapment screen from the water intake fitting on the pool wall.

NOTE: Figure 1 shows the intake for soft-side frame pools. Figure 2 displays the intake used with our speed set pools.

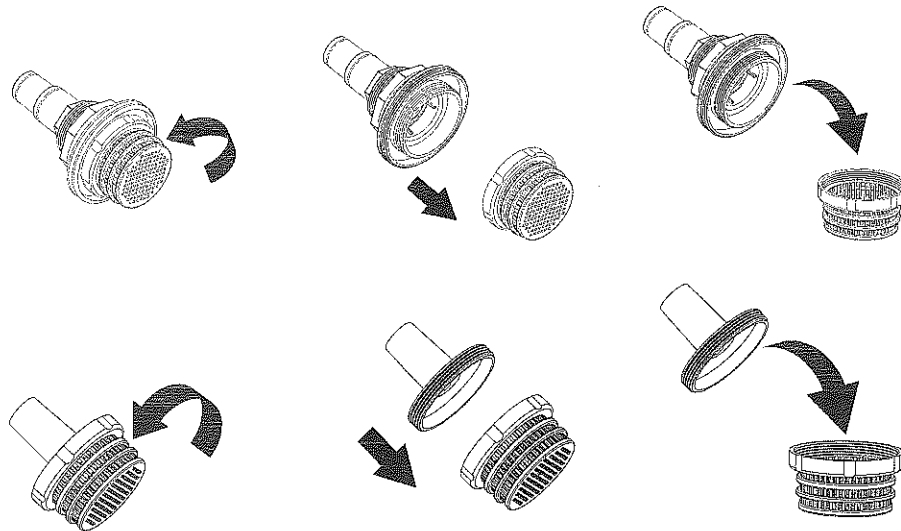

Figure 1

Figure 2

5. Insert the Vacuum Hose Adapter (Not Included)

6. Place the Base Vacuum Head in the pool. Be careful not to damage the liner. Slowly move the vacuum over the pool floor.

7. Dirt and debris will be vacuumed directly into the filter tank. Clean out the filter tank as necessary.

8. This concludes the instructions for cleaning with the Base Vacuum Head.

90-DAY LIMITED WARRANTY

This product is warranted to the original purchaser to be free from defects in material or workmanship for a period of ninety (90) days from the date of the original retail purchase.

This warranty does not cover defects or damage due to improper installation, alteration, accident, or any other event beyond the control of the manufacturer. Defects or damage resulting from misuse, abuse, or negligence will void this warranty. This warranty does not cover scratching or damage that may result from normal usage.

This product is not intended for institutional or commercial use; the manufacturer does not assume any liability for such use. Institutional or commercial use will void this warranty.

This warranty is nontransferable and is expressly limited to the repair or replacement of the defective product. During the warranty period, the manufacturer shall repair or replace defective parts at no cost to the purchaser. Shipping charges and insurance are not covered and are the responsibility of the purchaser. Labor charges and related expenses for removal, installation, or replacement of the product or components are not covered under this warranty.

The manufacturer reserves the right to make substitutions to warranty claims if parts are unavailable or obsolete.

The manufacturer shall not be liable for loss of use of the product or other consequential or incidental costs, expenses, or damages incurred by the consumer of any other use. The user assumes all risk of injury resulting from the use of this product.

This warranty is expressly in lieu of all other warranties, expressed or implied, including warranties of merchantability or fitness for use to the extent permitted by Federal or state law. Neither the manufacturer nor any of its representatives assumes any other liability in connection with this product.

All warranty claims must be made through the retailer where the product was originally purchased. A purchase receipt or other proof of date of purchase will be required to process all warranty claims. The model number and part numbers found within the assembly instructions will be required when submitting any parts requests or warranty claims.