

| 1.0 Reference and Address | | | |
|---------------------------|---|------------------------------|---|
| Report Number | 160126188GZU-001 | Original Issued: 11-Mar-2016 | Revised: None |
| Standard(s) | UL 1310 Issued: 2011/08/26 Ed 6 Rev: 2014/12/12 Class 2 Power Units CSA C22.2 NO. 223 Issued: 1991/06/30 (R2013) Power Supplies with Extra-Low-Voltage Class 2 Outputs; Gen. Inst. No. 1: 1991, Gen. Inst. No. 2: 2009 | | |
| Applicant | Shenzhen Huoniu Technology Co., Ltd. | Manufacturer | Shenzhen Huoniu Technology Co., Ltd. |
| Address | Block No.5, The 4th Industrial Zone, Xitian Community, Gongming Town, Guangming New District, SHENZHEN Guangdong 518106 CHINA | Address | Block No.5, The 4th Industrial Zone, Xitian Community, Gongming Town, Guangming New District, SHENZHEN Guangdong 518106 CHINA |
| Country | China | Country | China |
| Contact | Wen He | Contact | Wen He |
| Phone | 0755-29827899 | Phone | 0755-29827899 |
| FAX | 0755-28079166 | FAX | 0755-28079166 |
| Email | hewen@szhuoniu.com | Email | hewen@szhuoniu.com |

| 2.0 Product Description | |
|--------------------------------|---|
| Product | Class 2 Power Supply |
| Brand name |  |
| Description | The product covered by this report is a household, dry location use only power supply, direct plug-in power supply. |
| Models | HNBExxxxyyWv (xxx=030-150, yyy=010-120, v=U or X) |
| Model Similarity | <p>Model HNBExxxxyyWv:</p> <p>The “xxx” represents output voltage from “030”(3.0Vdc) to “150”(15.0Vdc), increments in steps of 0.1 V;</p> <p>The “yy” represents output current from “010”(100mA) to “120”(1200mA), increments in steps of 10mA;</p> <p>The last letter “v” denote type of plug , it can be: “U” or “X”, “U” means non-detachable USA plug, “X” means detachable plug.</p> <p>All models are similar except for type of plug, model number, enclosure color, rating and electrical parameters of some components.</p> |
| Ratings | Input: AC 100-240V~, 50/60Hz, 0.3A MAX Output: 3-15Vdc, 100-1200mA, 7.5W MAX. |
| Other Ratings | Ta=25℃ |

3.0 Product Photographs

Photo 1 - Overall view of the unit for detachable plug model



1

Photo 2 - Overall view of the unit for detachable plug model



2

3.0 Product Photographs

Photo 3 - Overall view of the unit for non-detachable plug model



10

Photo 4 - Overall view of the unit for non-detachable plug model



3.0 Product Photographs

Photo 5 - Internal view of the unit

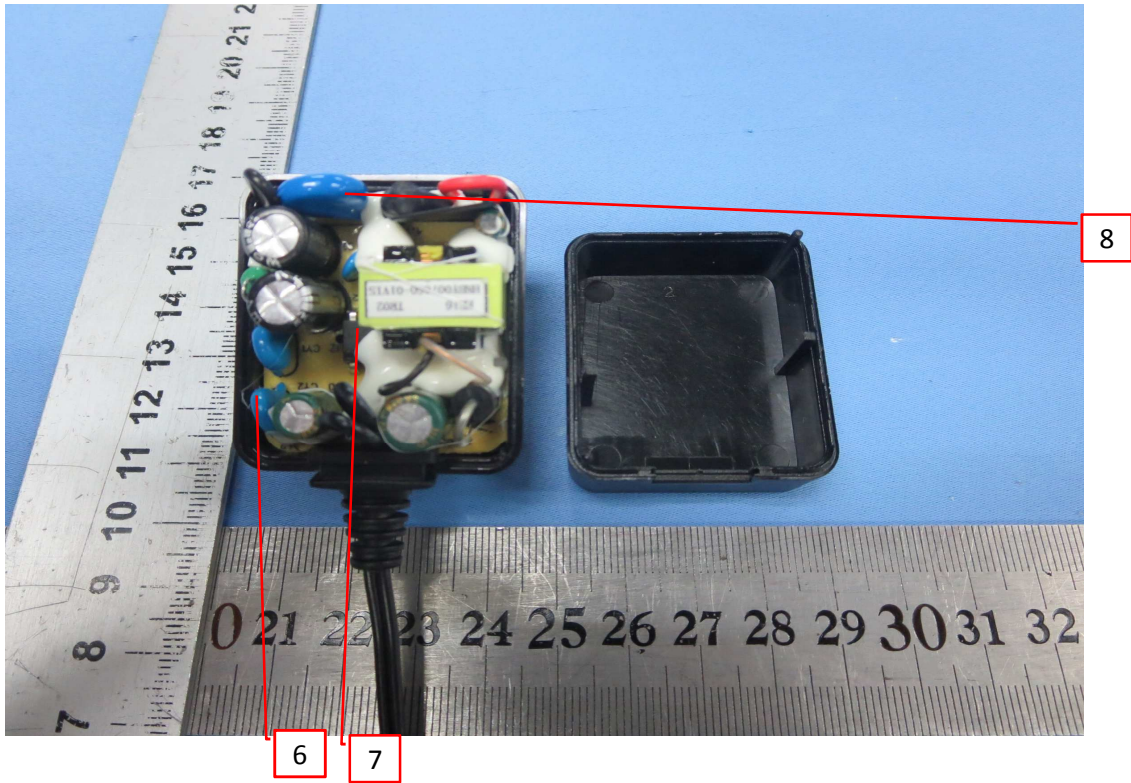
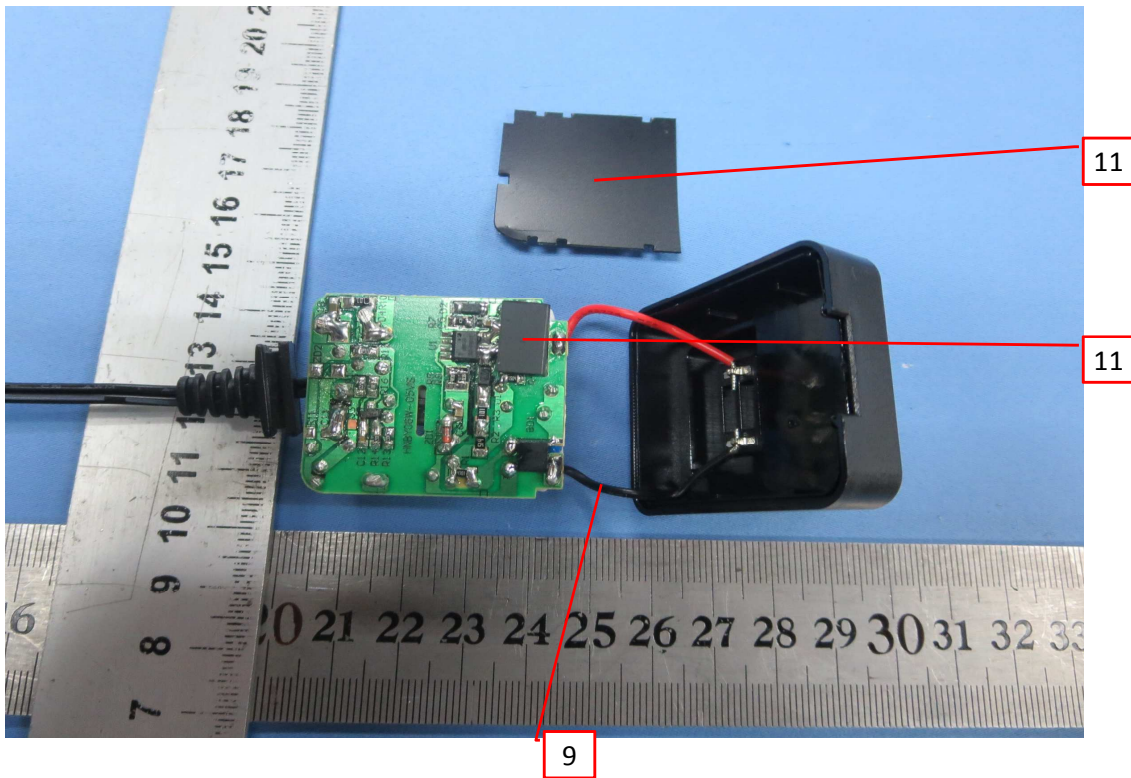

Photo 6 - Internal view of the unit



3.0 Product Photographs

Photo 7 - Internal view of the unit

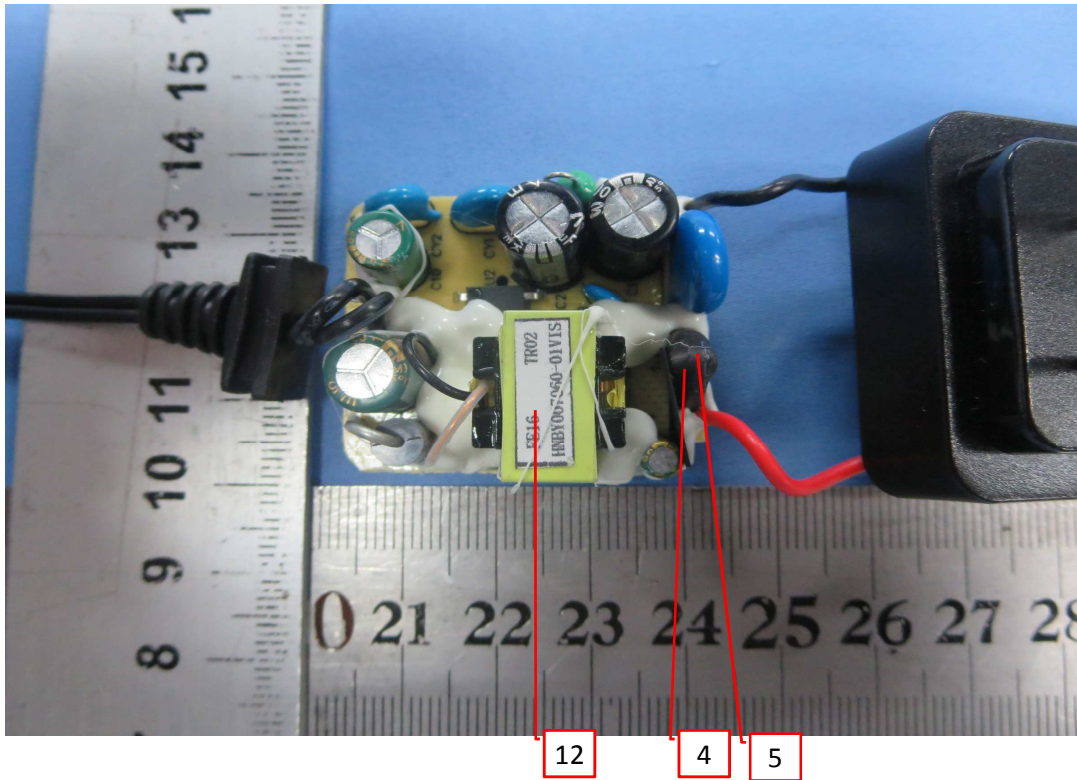
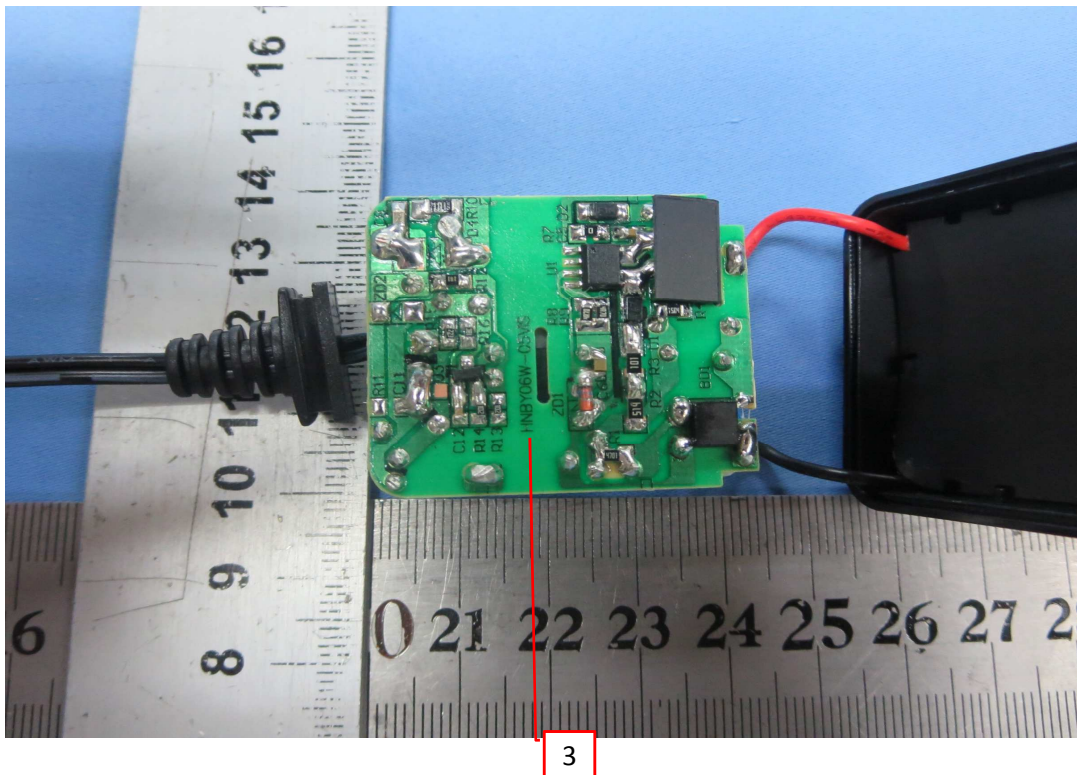

Photo 8- Internal view of the unit



3.0 Product Photographs

Photo 9- Transformer view

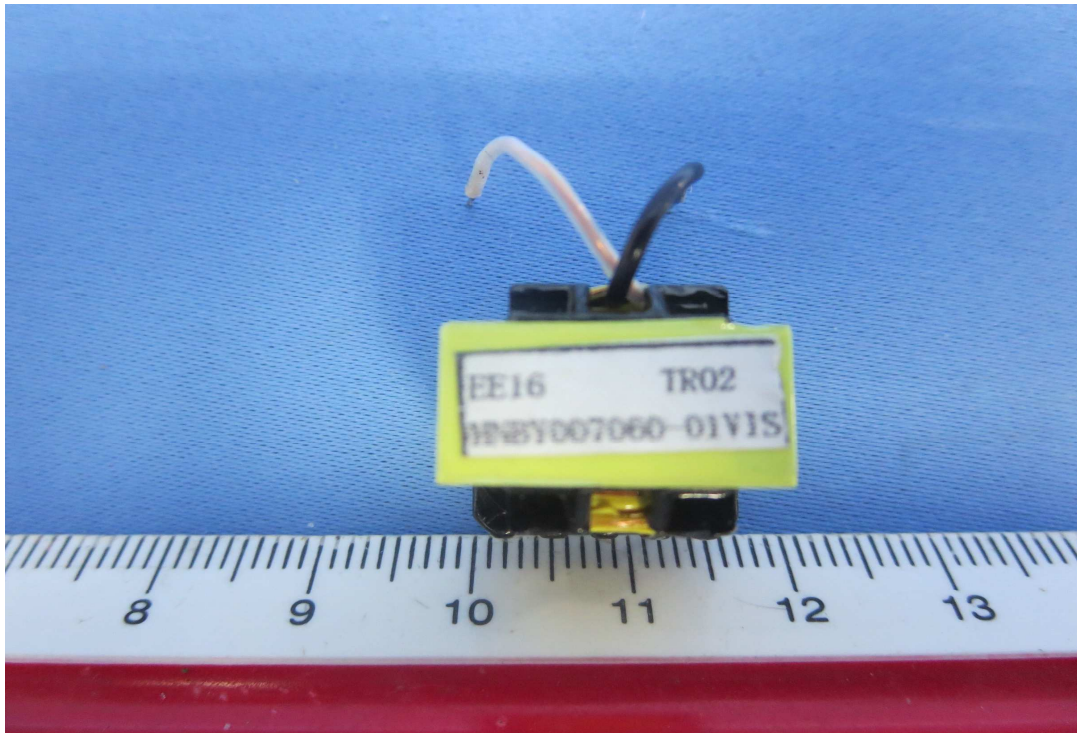
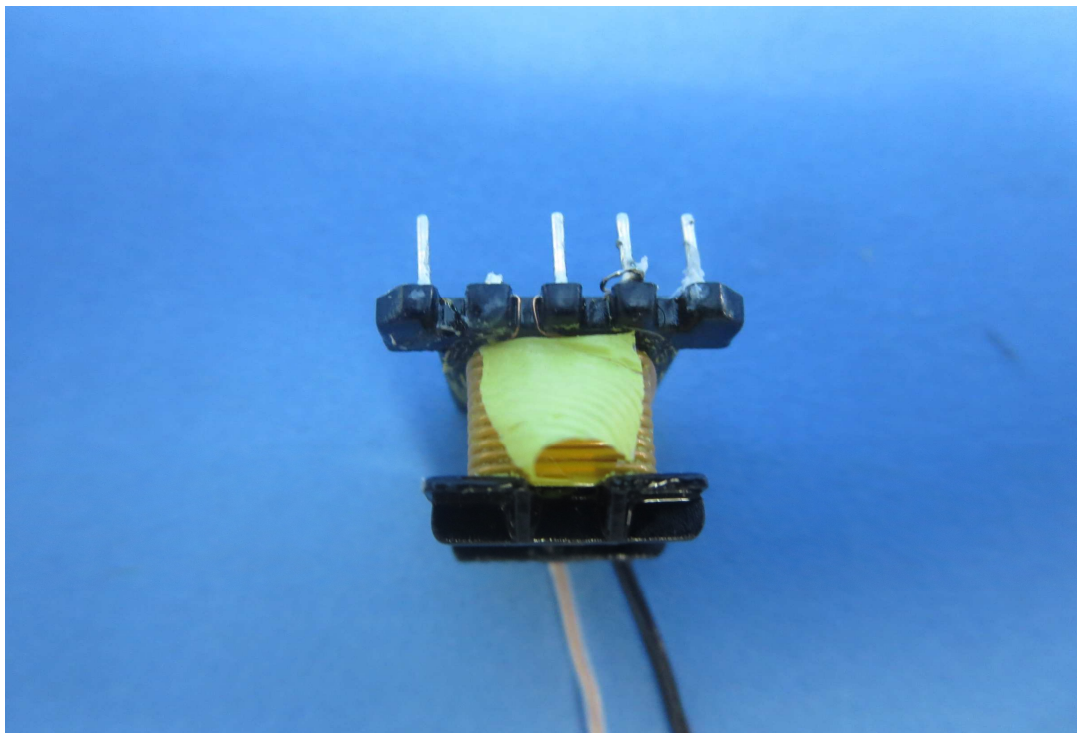

Photo 10- Transformer view



| 4.0 Critical Components | | | | | | |
|-------------------------|-----------------------|------------------------|---|------------------------------------|--------------------------------------|------------------------------------|
| Photo # | Item no. ¹ | Name | Manufacturer/ trademark ² | Type / model ² | Technical data and securement means | Mark(s) of conformity ³ |
| 1 | 1 | Enclosure | CHI MEI CORPORATION | PC-110N, PC-6610 | PC, V-0, 115°C, min thickness: 1.5mm | cURus |
| 2 | 2 | Plug holder | CHI MEI CORPORATION | PC-110N, PC-6610 | PC, V-0, 115°C | cURus |
| 8 | 3 | PCB | DONGGUAN CITY XINRAN ELECTRONIC CO LTD | XR-F003 | V-0, 130°C | cURus |
| | | | Various | Various | | cURus |
| 7 | 4 | Fusible resistor (FR1) | SHENZHEN GREAT ELECTRONICS CO LTD | RXF-1W Series | 4.7ohm, 1W | cURus |
| | | | DONGGUAN HONGDA ELECTRONIC TECHNOLOGY CO LTD | RXF series | | cURus |
| | | | Anhui Changsheng Electronics Co., Ltd | RXF21-1W | | cURus |
| 7 | 5 | Heat shrinkable tube | DONGGUAN SALIPT CO LTD | SALIPT S-901-600, SALIPT S-HPT-600 | 600V, 125°C | cURus |
| | | | GUANGZHOU KAIHENG NEW MATERIAL CO LTD | K-102 (+) | | cURus |
| | | | CHANGYUAN ELECTRONICS (SHENZHEN) CO LTD | CB-HFT | | cURus |
| | | | SHENZHEN WOER HEAT-SHRINKABLE MATERIAL CO LTD | RSFR, RSFR-H, RSFR-HPF | | cURus |

| 4.0 Critical Components | | | | | | |
|-------------------------|-----------------------|----------------------------|--|---------------------------|--|---------------------------------------|
| Photo # | Item no. ¹ | Name | Manufacturer/ trademark ² | Type / model ² | Technical data and securement means | Mark(s) of conformity ³ |
| 5 | 6 | Y-capacitor (CY1, CY2) | Shantou High-New Technology Dev. Zone Songtian Enterprise Co., Ltd. | CE | Max.2200pF, min.250 Vac, 125°C, Y2 type | cURus |
| | | | Walsin Technology Corporation | AC Series | | cURus |
| | | | SHENZHEN HAOTIAN ELECTRONIC CO LTD | HTC | | cURus |
| | | | WELSON INDUSTRIAL CO LTD | KL | | cURus |
| | | | GCE (DONGGUAN) ELECTRONICS CO LTD | G Y2 | | cURus |
| | | | DONGGUAN EASY-GATHER ELECTRONIC CO LTD | DCF | | cURus |
| | | | Various | Various | | cURus |
| 5 | 7 | Optocoupler (U2) | Bright Led Electronics Corp. | BPC -817 | Int. Cr / Ext. Cr / Dti: 7.6 mm / 8.0 mm / >0.4 mm, 110°C | cURus |
| | | | EVERLIGHT ELECTRONICS CO LTD | EL817 | Int. Cr / Ext. Cr / Dti: 6.0 mm / >7.5 mm / >0.5 mm, 110°C | cURus |
| | | | COSMO Electronics Corporation | KPC817, K1010, KP1010 | Int. Cr / Ext. Cr / Dti: 5.3 mm / 8.0 mm / 0.7 mm, 115°C | cURus |
| | | | Lite-On Technology Corporation | LVT-817 | Int. Cr / Ext. Cr / Dti: 5.2 mm / >7.8 mm / >0.8 mm, 110°C | cURus |
| 5 | 8 | Varistor (MOV1) (Optional) | THINKING ELECTRONIC INDUSTRIAL CO LTD | TVR10561-V/-B | min. 300Vac, min. 85°C | cURus |
| | | | BRIGHTKING (SHENZHEN) CO LTD | 10D561K | | cURus |
| | | | SHANTOU HIGH-NEW TECHNOLOGY DEVELOPMNT ZONE SONGTIAN ENTERPRISE CO LTD | 10D561K | | cURus |
| | | | SHAANXI HUAXING ELECTRONIC GROUP CO LTD | MYG20G10K56 1 | | cURus |

| 4.0 Critical Components | | | | | | |
|-------------------------|-----------------------|-----------------------|--|-------------------------------|--|------------------------------------|
| Photo # | Item no. ¹ | Name | Manufacturer/ trademark ² | Type / model ² | Technical data and securement means | Mark(s) of conformity ³ |
| 6 | 9 | Internal lead wire | Shenzhen Shi Yihuaxing Electron Co., Ltd. | 1672, 1007 | VW-1, 300V min., 80°C min., 22AWG Min. | cURus |
| | | | WONDERFUL HI-TECH CO LTD | 1430, 1672, 3385, 1007 | | cURus |
| | | | Kunshan Xinghongmeng Electronic Co., Ltd. | 1430, 1672, 3385, 1007 | | cURus |
| | | | XinYa Electronic Co., Ltd. | 1430, 1672, 3385, 1007 | | cURus |
| | | | Pacific Electric wire Cable Co., Ltd | 1430, 1672, 3385, 1007 | | cURus |
| | | | Yong hao electrical industry co ltd | 1672, 1007 | | cURus |
| | | | Various | 1430, 1672, 3385, 1007 | | cURus |
| 3 | 10 | Output cord | Shenzhen Shi Yihuaxing Electron Co., Ltd. | 2468, 2464, 1185 | PVC, 300V, 80°C, 22AWG Min. | cURus |
| | | | Various | 2468, 2464, 1185 | | cURus |
| 6 | 11 | Insulation sheet | CHENGDU KANGLONGXIN PLASTICS CO LTD | KLX FRPC-1880, KLX FRPC-1880B | V-0, 125°C. min thickness: 0.4mm | cURus |
| | | | FORMEX, DIV OF ILLINOIS TOOL WORKS INC, FORMERLY | FORMEX GK-(a)(b)(f2) | | cURus |
| 7 | 12 | Transformer (T1) | SHENZHEN OTEN TECHNOLOGY CO LTD | HNB Y007030-01VIS | Class B, see illustration No.4 (for output 3.0-4.9V) | NR |
| | | | SHENZHEN OTEN TECHNOLOGY CO LTD | HNB Y007060-01VIS | Class B, see illustration No.4a (for output 5.0-7.5V) | NR |
| | | | SHENZHEN OTEN TECHNOLOGY CO LTD | HNB Y007090-01VIS | Class B, see illustration No.4b (for output 9.0-15.0V) | NR |
| 7 | 12a | Bobbin | CHANG CHUN PLASTICS CO LTD | T375J, T375HF | Phenolic, 150°C, V-0 | cURus |
| | | | Sumitomo Bakelite Co., Ltd. | PM9820, PM9630 | | cURus |
| 7 | 12b | Magnet Wire (primary) | TONGLING NONFERROUS COPPER CROWN ELECTRICAL CO LTD | UEW | 130°C | cURus |
| | | | Various | Various | 130°C | cURus |

| 4.0 Critical Components | | | | | | |
|-------------------------|-----------------------|-----------------------|--|---------------------------|-------------------------------------|------------------------------------|
| Photo # | Item no. ¹ | Name | Manufacturer/ trademark ² | Type / model ² | Technical data and securement means | Mark(s) of conformity ³ |
| 7 | 12c | Triple insulated wire | Shenzhen Darun Science & Technology Co., Ltd | DRTIW-B | 130°C | cURus |
| | | | Furukawa Electric Co., Ltd. | TEX-E, TEX-B | | cURus |
| | | | Totoku Electric Co., Ltd. | TIW-2X, TIW-3X | | cURus |
| 7 | 12d | Insulation tape | 3M Company | 1350-1, 1350F-1, 1351-1 | 130°C | cURus |
| | | | BONDTEC PACIFIC CO LTD | 371F (a) | | cURus |
| | | | JINGJIANG YAHUA PRESSURE SENSITIVE GLUE CO LTD | CT, PZ, WF | | cURus |
| | | | XINYU SHENGDAFENG ELECTRIC MATERIAL CO LTD | SDF-312 | | cURus |
| 7 | 12e | Teflon Tube | Zeus industrial products inc | TFE-TW-300, TFE-SW-600 | 200°C, min.300V | cURus |
| | | | GREAT HOLDING INDUSTRIAL CO LTD | TFT, TFS | | cURus |
| | | | CHANGYUAN ELECTRONICS GROUP CO LTD | CB-TT-T CB-TT-S | | cURus |
| | | | SHENZHEN ZHONGDIANCHE NGUANG ELECTRONIC CO LTD | CG-T, CG-S | | cURus |
| 7 | 12f | Varnish | HANG CHEUNG PETROCHEMICAL LTD | 8562* | 130°C | UR |
| | | | HITACHI CHEMICAL CO.,LTD | WP-2952F-2G | 130°C | UR |
| | | | SHENZHEN EASTLIGHT CHEMICAL CO LTD | DFL-8033-(a) | 180°C | UR |
| 3 | 13 | Label (not shown) | Various | Various | 75°C, suitable for plastic | cURus |

NOTES:

- 1) Not all item numbers are indicated (called out) in the photos, as their location is obvious.
- 2) "Various" means any type, from any manufacturer that complies with the "Technical data and securement means" and meets the "Mark(s) of conformity" can be used.
- 3) Indicates specific marks to be verified, which assures the agreed level of surveillance for the component. "NR" - indicates Unlisted and only visual examination is necessary. "See 5.0" indicates Unlisted components or assemblies to be evaluated periodically refer to section 5.0 for details.

5.0 Critical Unlisted CEC Components

No Unlisted CEC components are used in this report.

6.0 Critical Features

Recognized Component - A component part, which has been previously evaluated by an accredited certification body with restrictions and must be evaluated as part of the basic product considering the restrictions as specified by the Conditions of Acceptability.

Listed Component - A component part, which has been previously Listed or Certified by an accredited Certification Organization with no restrictions and is used in the intended application within its ratings.

Unlisted Component - A part that has not been previously evaluated to the appropriate designated component standard. It may also be a Listed or Recognized component that is being used outside of its evaluated Listing or component recognition.

Critical Features/Components - An essential part, material, subassembly, system, software, or accessory of a product that has a direct bearing on the product's conformance to applicable requirements of the product standard.

Construction Details - For specific construction details, reference should be made to the photographs and descriptions. All dimensions are approximate unless specified as exact or within a tolerance. In addition to the specific construction details described in this Report, the following general requirements also apply.

1. Spacing - In primary circuits, 2.0/2.4 mm minimum spacing are maintained through air and over surfaces of insulating material between current-carrying parts of opposite polarity and 4.8/4.8 mm minimum between such current-carrying parts and dead-metal parts or low voltage isolated circuits.
2. Mechanical Assembly - Components such as switches, fuseholders, connectors, wiring terminals and display lamps are mounted and prevented from shifting or rotating by the use of lockwashers, starwashers, or other mounting format that prevents turning of the component.
3. Corrosion Protection - All ferrous metal parts are protected against corrosion by painting, plating or the equivalent.
4. Accessibility of Live Parts - All uninsulated live parts in primary circuitry are housed within a non-metallic enclosure constructed with no openings other than those specifically described in Sections 4 and 5.
5. Grounding - This product is not provided with a means of grounding as it is double insulated.
6. Polarized Connection - This product is provided with a non-polarized power supply connection.
7. Internal Wiring - Internal wiring is routed away from sharp or moving parts. Internal wiring leads terminating in soldered connections are made mechanically secure prior to soldering. Recognized Component separable (quick disconnect) connectors of the positive detent type, closed loop connectors, or other types specifically described in the text of this report are also acceptable as internal wiring terminals. At points where internal wiring passes through metal walls or partitions, the wiring insulation is protected against abrasion or damage by plastic bushings or grommets.
8. Schematics - Refer to Illustration No. 2 for schematics requiring verification during Field Representative Inspection Audits.
9. Markings - The product is marked on a labeling system as follows:
 - manufacturer's name, trade name or trade mark
 - model number
 - electrical ratings (volts, input power & frequency)Refer to Illustration No. 1 for details.
10. Cautionary Markings - The following are required: Refer to Illustration No.1, shown the molded caution content both in English and French.
11. Installation, Operating and Safety Instructions - Instructions for installation and use of this product are provided by the manufacturer. Refer to Illustration No.5 for details. The use manual in French must provide when the unit sell to Cannada.

7.0 Illustrations

Illustration 1 - Marking (representative)

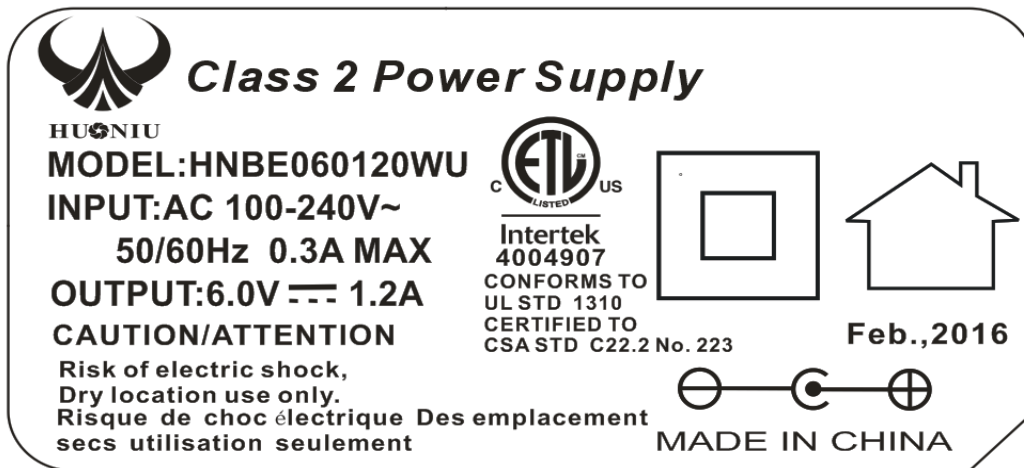
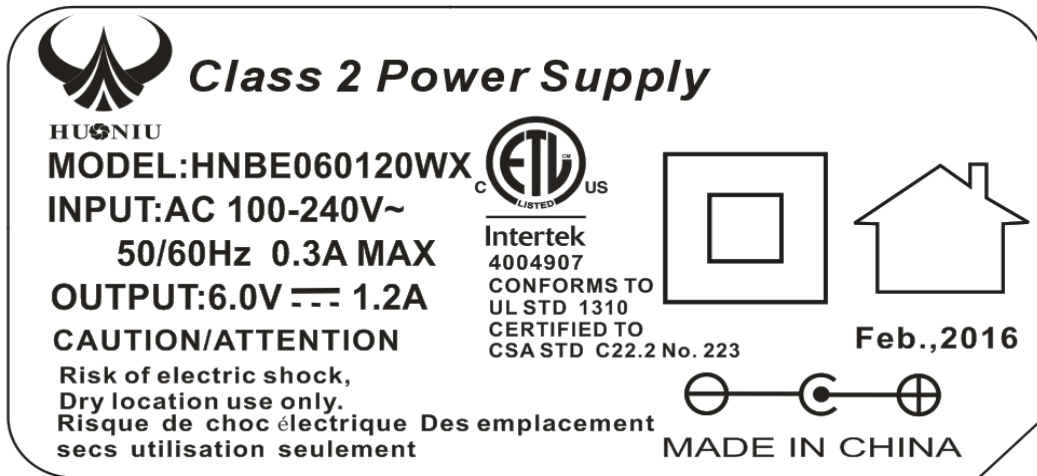

Note:

1. The above markings are the minimum requirements required by the safety standard. For the final production samples, the additional markings which do not give rise to misunderstanding may be added.
2. "CAUTION/ATTENTION" shall be at least 3.2 mm high. "Risk of Electric Shock", "Dry location use only" shall be at least 1.6 mm high.
3. The other models(refer to 2.0) have the same labels except model number and rating.
- 4."Feb.,2016" means that the product is produced in month February, year 2016.

7.0 Illustrations

Illustration 2 - Schematic

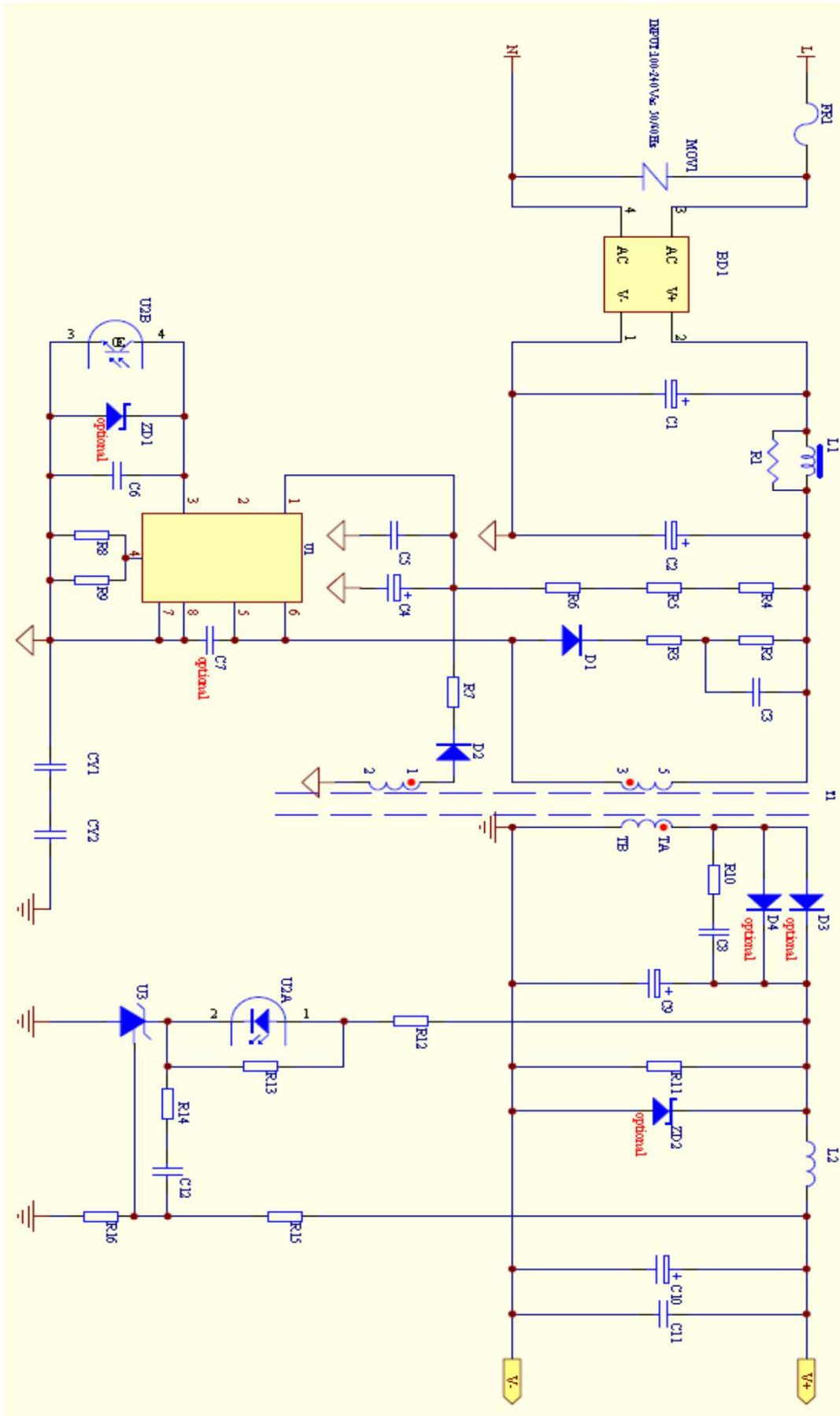

7.0 Illustrations

Illustration 3 - PCB Layout

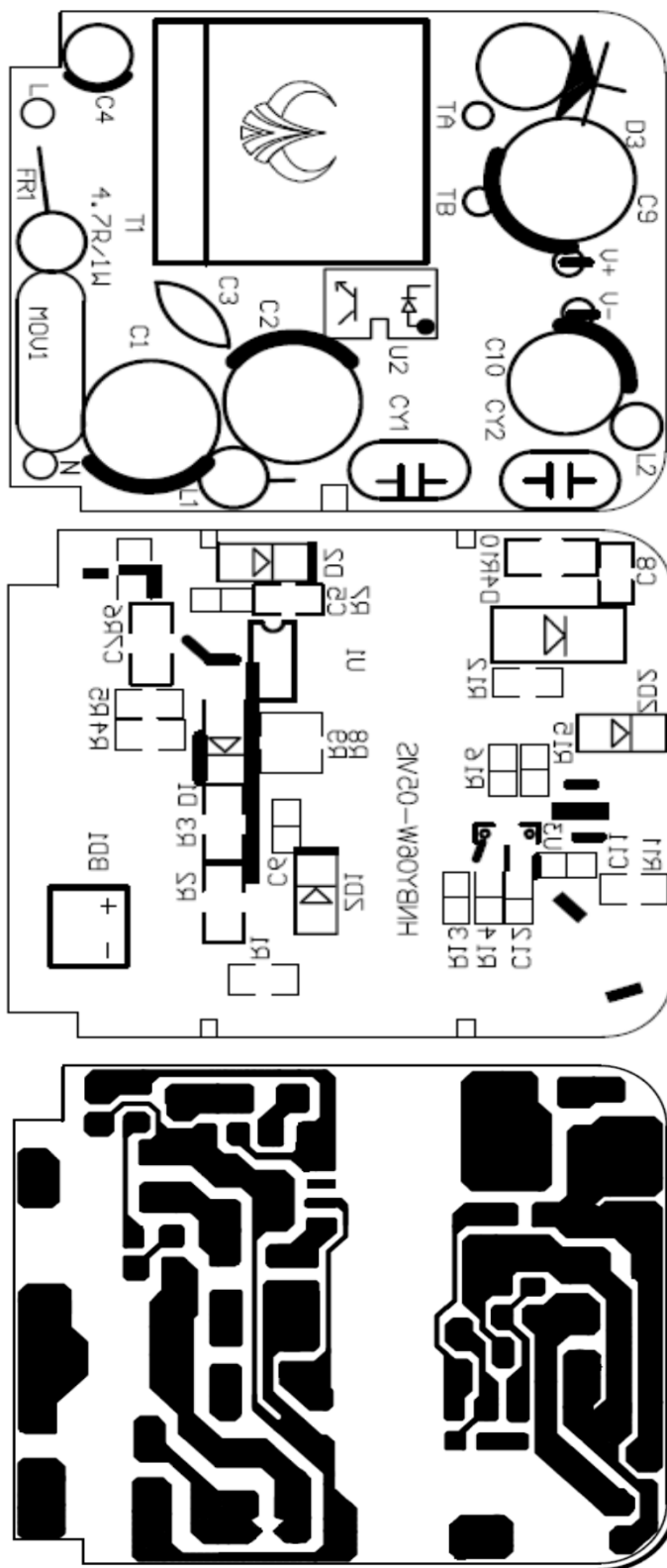

7.0 Illustrations

Illustration 4 - Transformer specification of model HNB Y007030-01VIS

1. MECHANICAL DIMENSION (UNIT:mm)

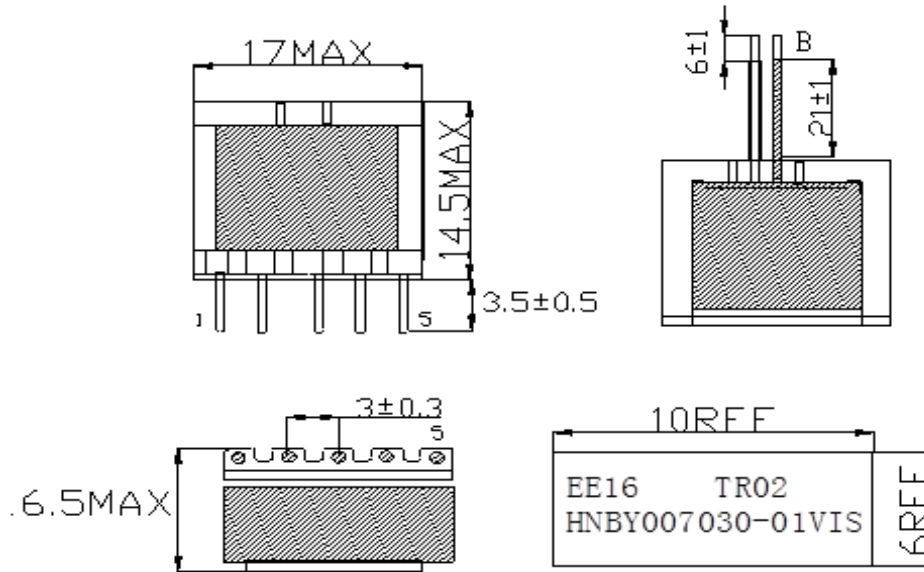

2. SCHEMATIC

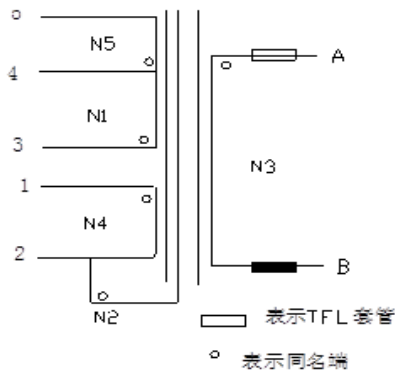

3.WIDING CONSTRUCTION

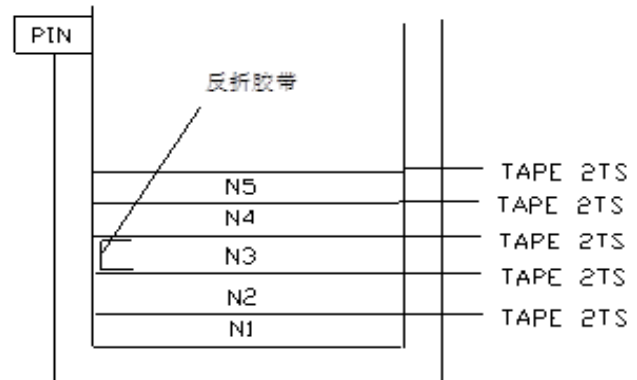

4.WINDING INFORMATION

| No. | Terminal | Wire Gauge | Turns | Tape | Remarks |
|-----|----------|--------------------|-------|------|---------|
| N1 | 3--4 | ZUEW Φ 0.13mmx1P | 85Ts | 2Ts | 密绕两层 |
| N2 | 2--NC | ZUEW Φ 0.13mmx1P | 40Ts | 2Ts | 密绕一层 |
| N3 | A--B | DRTIW-B Φ 0.4mmx1P | 10Ts | 2Ts | 密绕一层 |
| N4 | 1--2 | ZUEW Φ 0.13mmx1P | 38Ts | 2Ts | 密绕一层 |
| N5 | 4--5 | ZUEW Φ 0.13mmx1P | 40Ts | 2Ts | 密绕一层 |

Remarks

1. 绕制装夹方向针脚朝右。
2. A, B为飞线, 从顶部引出, A加白色套管, B加黑色套管, 飞线长度出骨架 (长度如图)
绕N3时在1--5脚边贴一片反折胶带, PIN2脚留一条线接磁芯底部。
3. 研磨磁芯放在针脚端, 磁芯包胶纸8mm×2Ts, 产品全部真空浸油,。
4. 标签贴于顶部, 字底朝下, 产品要求环保符合RoHS。

5.ELECTRICAL SPECIFICATION

| No. | Item | Measured Point | Technical Data | Test Condition & Instrument |
|-----|------------|----------------|----------------|-----------------------------|
| 1 | Inductance | 3--5 | 5.0mH Max. | CH1062(10KHz, 0.3V) |
| 2 | Lk | 3--5 | 100uH MAX | CH1062(10KHz, 0.3V) |
| 3 | HI-POT | P--S | 3750V AC | CS2670 5mA, 60S |
| | | S--C | 1500V AC | |

7.0 Illustrations

Illustration 4a - Transformer specification of model HNBY007060-01VIS

1. MECHANICAL DIMENSION (UNIT:mm)

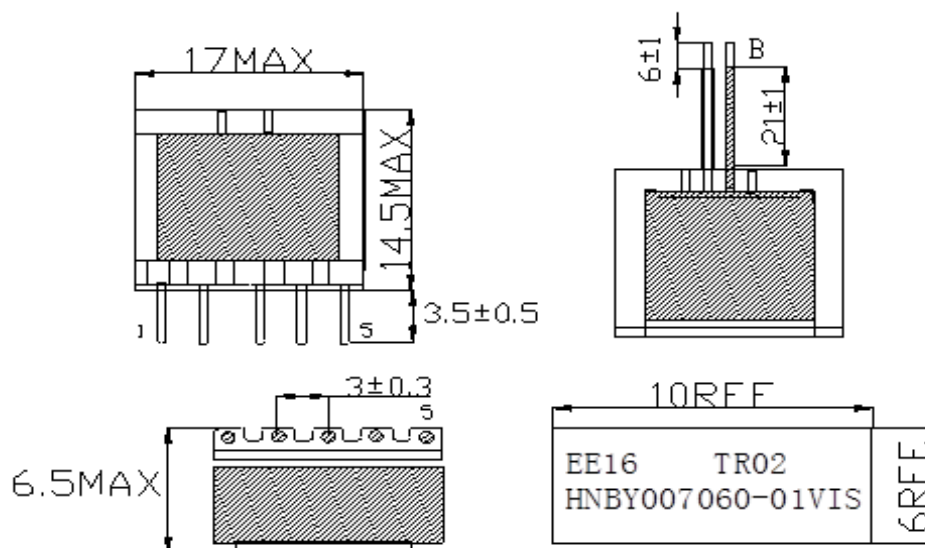

2. SCHEMATIC

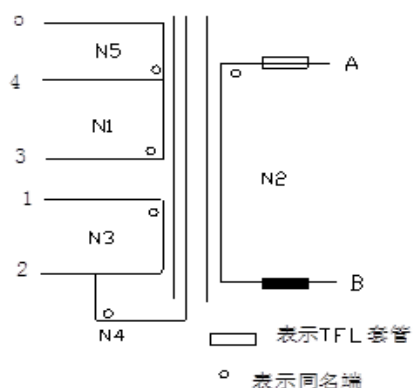

3.WIDING CONSTRUCTION

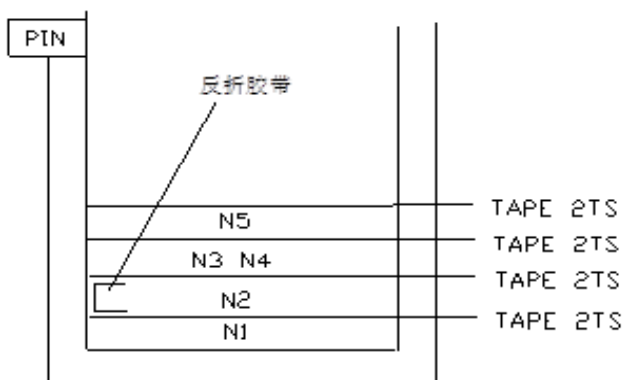

4.WINDING INFORMATION

| No. | Terminal | Wire Gauge | Turns | Tape | Remarks |
|-----|----------|--------------------|-------|------|------------|
| N1 | 3--4 | 2UEW Φ 0.13mmx1P | 85Ts | 2Ts | 密绕两层 |
| N2 | A--B | DRTIW-B Φ 0.4mmx1P | 10Ts | 2Ts | 密绕一层 |
| N3 | 1--2 | 2UEW Φ 0.12mmx1P | 22Ts | 2Ts | 密绕一层（同层并绕） |
| N4 | 2--NC | 2UEW Φ 0.12mmx1P | | | |
| N5 | 4--5 | 2UEW Φ 0.13mmx1P | 40Ts | 2Ts | 密绕一层 |

Remarks

- 绕制装夹方向针脚朝右。
- A, B为飞线, 从顶部引出, A加白色套管, B加黑色套管, 飞线长度出骨架 (长度如图)
绕N2时在1--5脚边贴一片反折胶带, PIN2脚留一条线接磁芯底部。
- 研磨磁芯放在针脚端, 磁芯包胶纸8mm×2Ts, 产品全部真空浸油。
- 标签贴于顶部, 字底朝下, 产品要求环保符合RoHS。

5.ELECTRICAL SPECIFICATION

| No. | Item | Measured Point | Technical Data | Test Condition & Instrument |
|-----|------------|----------------|----------------|-----------------------------|
| 1 | Inductance | 3--5 | 5.0mH Max. | CH1062(10KHz, 0.3V) |
| 2 | Lk | 3--5 | 100uH MAX | CH1062(10KHz, 0.3V) |
| 3 | HI-POT | P--S | 3750V AC | CS2670 5mA, 60S |
| | | S--C | 1500V AC | |

7.0 Illustrations

Illustration 4b - Transformer specification of model HNB Y007090-01VIS

1. MECHANICAL DIMENSION (UNIT:mm)

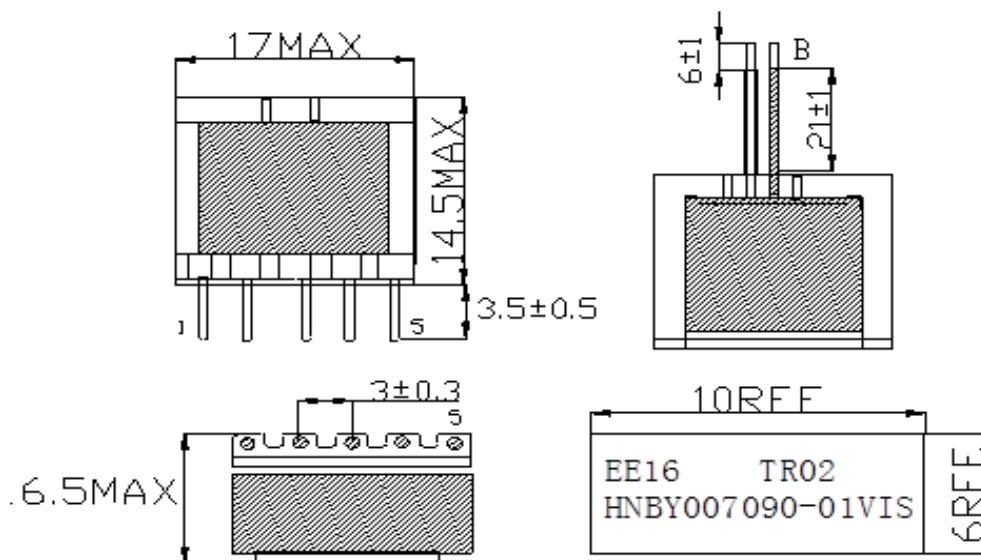

2. SCHEMATIC

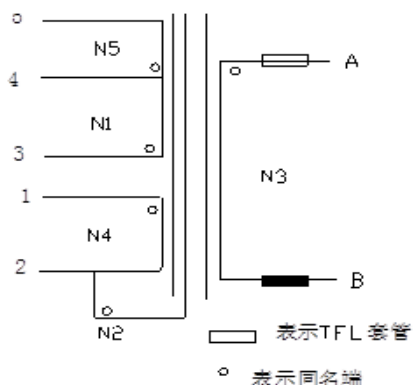

3.WIDING CONSTRUCTION

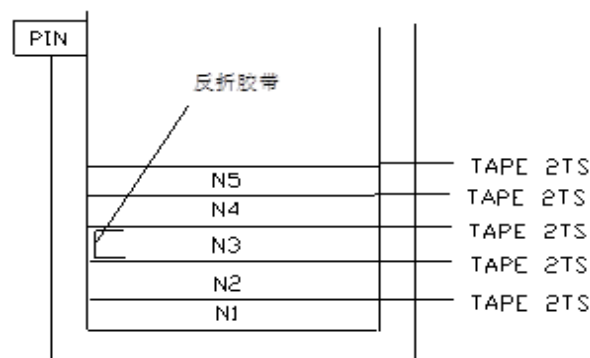

4.WINDING INFORMATION

| No. | Terminal | Wire Gauge | Turns | Tape | Remarks |
|-----|----------|--------------------|-------|------|---------|
| N1 | 3--4 | 2UEW Φ 0.13mmx1P | 85Ts | 2Ts | 密绕两层 |
| N2 | 2--NC | 2UEW Φ 0.13mmx1P | 40Ts | 2Ts | 密绕一层 |
| N3 | A--B | DRTIW-B Φ 0.4mmx1P | 18Ts | 2Ts | 密绕两层 |
| N4 | 1--2 | 2UEW Φ 0.13mmx1P | 24Ts | 2Ts | 居中密绕 |
| N5 | 4--5 | 2UEW Φ 0.13mmx1P | 40Ts | 2Ts | 密绕一层 |

Remarks

1. 绕制装夹方向针脚朝右。
2. A, B为飞线, 从顶部引出, A加白色套管, B加黑色套管, 飞线长度出骨架 (长度如图)
绕N3时在1--5脚边贴一片反折胶带, PIN2脚留一条线接磁芯底部。
3. 研磨磁芯放在针脚端, 磁芯包胶纸8mm×2Ts, 产品全部真空浸油,。
4. 标签贴于顶部, 字底朝下, 产品要求环保符合RoHS。

5.ELECTRICAL SPECIFICATION

| No. | Item | Measured Point | Technical Data | Test Condition & Instrument |
|-----|------------|----------------|----------------|-----------------------------|
| 1 | Inductance | 3--5 | 5.0mH Max. | CH1062(10KHz, 0.3V) |
| 2 | Lk | 3--5 | 100uH MAX | CH1062(10KHz, 0.3V) |
| 3 | HI-POT | P--S | 3750V AC | CS2670 5mA, 60S |
| | | S--C | 1500V AC | |

7.0 Illustrations

Illustration 5 - User manual (representative)

User manual

Class 2 Power Supply

Model: HNBE060120WU

Input: AC 100-240V~, 50/60Hz, 0.3A MAX

Output: 6Vdc, 1200mA

To comply with the published safety standards, the following must be observed when using this Class 2 Power Supply

Note:

IMPORTANT SAFETY INSTRUCTIONS-SAVE THESE INSTRUCTIONS and DANGER-TO REDUCE THE RISK OF FIRE OR ELECTRIC SHOCK,CAREFULLY FOLLOW THESE INSTRUCTIONS.

1. The Power supply is certified according to the relevant safety standards UL1310.
2. Please read these safety instructions carefully.
3. Please keep this User's Manual for later reference.
4. Please disconnect this equipment from AC outlet before cleaning. Don't use liquid or sprayed detergent for cleaning. Use moisture sheet or clothe for cleaning.
5. For pluggable equipment, the socket-outlet shall be installed near the equipment and shall be easily accessible.
6. Please keep this equipment from humidity.
7. Make sure the voltage of the power source when connect the equipment to the power outlet.
8. All cautions and warnings on the equipment should be noted.
9. If the equipment is not use for long time, disconnect the equipment from mains to avoid being damaged by transient over-voltage.
10. Never open the equipment. For safety reason, qualified service personnel should only open the equipment.
11. If one of the following situations arises, get the equipment checked by service personnel:
 - a. Liquid has penetrated into the equipment.
 - b. The equipment has been exposed to moisture.
 - c. The equipment has not work well or you can not get it work according to user's manual.
 - d. The equipment has dropped and damaged.
 - e. If the equipment has obvious sign of breakage
12. Do not leave this equipment in an environment unconditioned, storage temperature above 40 °C, it may damage the equipment.
13. The power supply shall be installed according to specification.
14. For connection to a supply not in the U.S.A., use an attachment plug adapter of the proper configuration for the power outlet, if needed. Or, If the shape of the plug does not fit the power outlet, use an attachment plug adaptor of the proper configuration for the power outlet.
15. If a power unit is intended for use in a country other than the U.S.A, the detachable power supply cord shall comply with the requirements of the country of destination.

Manufacturer name: Shenzhen Huoniu Technology Co., Ltd.

Manufacturer address: Block No.5, The 4th Industrial Zone, Xitian Community, Gongming Town,
Guangming New District, SHENZHEN Guangdong 518106 CHINA

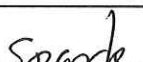
| 8.0 Test Summary | | | |
|---|---|---|--|
| Evaluation Period | 26-Jan-2016 to 26-Feb-2016 | | Project No. 160126188GZU |
| Sample Rec. Date | 26-Jan-2016 | Condition Prototype | Sample ID. S160126188-001~011 |
| Test Location | Intertek Testing Services Shenzhen Ltd. Guangzhou Branch (Address: Block E, No.7-2 Guang Dong Software Science Park, Caipin Road, Guangzhou Science City, GETDD, Guangzhou, China) | | |
| Test Procedure | Testing Lab | | |
| Determination of the result includes consideration of measurement uncertainty from the test equipment and methods. The product was tested as indicated below with results in conformance to the relevant test criteria. | | | |
| The following tests were performed: | | | |
| Test Description | UL 1310 Issued: 2011/08/26 Ed 6 Rev: 2014/12/12 Class 2 Power Units Clause | CSA C22.2#223 Issued: 1991/06/30 (R2013) Power Supplies with Extra-Low-Voltage Class 2 Outputs; Gen. Inst. No. 1: 1991, Gen. Inst. No. 2: 2009 Clause | UL 746C Issued: 2004/09/10 Ed: 6 Rev: 2015/06/23 Polymeric Materials - Used in Electrical Equipment Evaluations Clause |
| Leakage Current Test | 26 | 6.5 | -- |
| Leakage Current Test and Dielectric Voltage Withstand Test after Humidity Exposure | 27 | -- | -- |
| Maximum Output Voltage Test / | 28 | 6.2.1 | -- |
| Maximum Input Test / Rated Input | 29 | 6.2.2 | -- |
| Output Current and Power Test / | 30 | 6.2.4 | -- |
| Full-Load Output Current Test / Rated Output | 32 | 6.2.3 | -- |
| Normal Temperature Test / Temperature (Normal) | 33 | 6.3 | -- |
| Dielectric Voltage Withstand Test / Dielectric Strength | 34 | 6.4 | -- |
| Secondary Circuit Protection | -- | 6.6 | -- |
| Abnormal Operation Test – Output Loading Test | 39.2 | -- | -- |
| Abnormal Operation Test – Transformer Burnout Test | 39.4 | -- | -- |
| Abnormal Operation Test – Component Breakdown / Abnormal Test | 39.7 | 6.7 | -- |
| Abnormal Operation Test – Printed Wiring Board | 39.8 | -- | -- |
| Tests on Insulating Materials | 40 | 6.13 | -- |
| Strain Relief Test | 41 | 6.10 | -- |
| Direct Plug-In Blade Secureness Test | 43 | 6.10 | -- |
| Direct Plug-In Security of Input Contacts Test | 44 | 6.10 | -- |
| Impact on Direct Plug-In Units | 46.2 | 6.9 | -- |
| Rod Pressure on Direct Plug-In Units | 46.4 | -- | -- |
| Resistance to Crushing on Direct Plug-In Units | 46.5 | -- | -- |
| Securement of Components: | -- | 6.12 | -- |
| Normal input test | 50.2 | -- | -- |
| Mold stress-relief distortion test | -- | -- | 29 |
| Strain Relief Test After Mold Stress-Relief Distortion | -- | -- | 31 |
| 8.1 Signatures | | | |
| A representative sample of the product covered by this report has been evaluated and found to comply with the applicable requirements of the standards indicated in Section 1.0. | | | |
| Completed by: | Aaron Yi | Reviewed by: | Spark He |
| Title: | Engineer | Title: | Technical Team Leader |
| Signature: |  | Signature: |  |

9.0 Correlation Page For Multiple Listings

The following products, which are identical to those identified in this report except for model number and Listee name, are authorized to bear the ETL label under provisions of the Intertek Multiple Listing Program.

| | |
|--------------|---|
| BASIC LISTEE | Shenzhen Huoniu Technology Co., Ltd. |
| Address | Block No.5, The 4th Industrial Zone, Xitian Community, Gongming Town, Guangming New District, SHENZHEN Guangdong 518106 CHINA |
| Country | China |
| Product | Class 2 Power Supply |

| | |
|-------------------|------|
| MULTIPLE LISTEE 1 | None |
| Address | |
| Country | |
| Brand Name | |

| | |
|-------------------------|--|
| ASSOCIATED MANUFACTURER | |
| Address | |
| Country | |

| | |
|--------------------------|---------------------|
| MULTIPLE LISTEE 1 MODELS | BASIC LISTEE MODELS |
| | |

| | |
|-------------------|------|
| MULTIPLE LISTEE 2 | None |
| Address | |
| Country | |
| Brand Name | |

| | |
|-------------------------|--|
| ASSOCIATED MANUFACTURER | |
| Address | |
| Country | |

| | |
|--------------------------|---------------------|
| MULTIPLE LISTEE 2 MODELS | BASIC LISTEE MODELS |
| | |

| | |
|-------------------|------|
| MULTIPLE LISTEE 3 | None |
| Address | |
| Country | |
| Brand Name | |

| | |
|-------------------------|--|
| ASSOCIATED MANUFACTURER | |
| Address | |
| Country | |

| | |
|--------------------------|---------------------|
| MULTIPLE LISTEE 3 MODELS | BASIC LISTEE MODELS |
| | |

10.0 General Information

The Applicant and Manufacturer have agreed to produce, test and label ETL Listed products in accordance with the requirements of this Report. The Manufacturer has also agreed to notify Intertek and to request authorization prior to using alternate parts, components or materials.

COMPONENTS

Components used shall be those itemized in this Intertek report covering the product, including any amendments and/or revisions.

LISTING MARK

The ETL Listing mark applied to the products shall either be separable in form, such as labels purchased from Intertek, or on a product nameplate or other media only as specifically authorized by Intertek. Use of the mark is subject to the control of Intertek.

The mark must include the following four items:

- 1) applicable country identifiers "US" and/or "C" or "US", "C" and "EU"
- 2) the word "Listed" or "Classified" or "Recognized Component" (whichever is appropriate)
- 3) a control number issue by Intertek
- 4) a product descriptor that identifies the standards used for certification. Example:

For US standards, the words, "Conforms to" shall appear with the standard number along with the word, "Standard" or "Std." Example: "Conforms to ANSI/UL Std. XX."

For Canadian standards, the words "Certified to CAN/CSA Standard CXX No. XX." shall be used, or abbreviated, "Cert. to CAN/CSA Std. CXX No. XX."

Can be used together when both standards are used.

Note: A facsimile must be submitted to Intertek, Attn: Follow-up Services for approval prior to use. The facsimile need not have a control number. A control number will be issued after signed Certification Agreements have been received by the Follow-up Services office, approval of the facsimile of your proposed Listing Mark, satisfactory completion of the Listing Report, and scheduling of a factory

MANUFACTURING AND PRODUCTION TESTS

Manufacturing and Production Tests shall be performed as required in this Report.

FOLLOW-UP SERVICE

Periodic unannounced audits of the manufacturing facility (and any locations authorized to apply the mark) shall be scheduled by Intertek. An audit report shall be issued after each visit. Special attention will be given to the following:

1. Conformance of the manufactured product to the descriptions in this Report.
2. Conformance of the use of the ETL mark with the requirements of this Report and the Certification Agreement.
3. Manufacturing changes.
4. Performance of specified Manufacturing and Production Tests.

In the event that the Intertek representative identifies non-conformance(s) to any provision of this Report, the Applicant shall take one or more of the following actions:

1. Correct the non-conformance.
2. Remove the ETL Mark from non-conforming product.
3. Contact the issuing product safety evaluation center for instructions.

10.1 Evaluation of Unlisted Components

Because Unlisted Components are uncontrolled, and they do not fall under a third party follow up program, Intertek may require these components to be tested and/or evaluated at least once annually, more often for certain components, as part of the independent certification process. The Unlisted Components in Section 5.0 require testing and/or evaluation as indicated.

Note to Intertek Follow Up Inspector: The Component Evaluation Center, CEC, will notify you in writing when these components must be selected and sent to the CEC for re-evaluation

Ship the samples to:
Intertek Testing Services Shenzhen Limited Guangzhou Branch
ETL Component Evaluation Center
Block E, No. 7-2 Guang Dong Software Science Park, Caipin Road, Guangzhou Science City
CETDD Guangzhou, China.
Attn: Ms. Joey Kuang
Sample Disposition: Due to the destructive nature of the testing, all samples will be discarded at the conclusion of testing unless, the manufacturer specifically requests the return of the samples. The request for return must accompany the initial component shipment.

11.0 Manufacturing and Production Tests

The manufacturer agrees to conduct the following Manufacturing and Production Tests as specified:

Required Tests

Dielectric Voltage Withstand Test

11.1 Dielectric Voltage Withstand Test

Method

One hundred percent of production of the products covered by this Report shall be subjected to a routine production line dielectric withstand test.

The test shall be conducted on products, which are fully assembled. Prior to applying the test potential, all switches, contactors, relays, etc., should be closed so that all primary circuits are energized by the test potential. If all primary circuits cannot be tested at one time, then separate applications of the test potential shall be made.

The test voltage specified below shall be applied between primary circuits and accessible dead-metal parts. The test voltage may be gradually increased to the specified value but must be maintained at the specified value for one second or one minute as required.

Test Equipment

The test equipment shall incorporate a transformer with an essentially sinusoidal output, a means to indicate the applied test potential, and an audible and/or visual indicator of dielectric breakdown.

The test equipment shall incorporate a voltmeter in the output circuit to indicate directly the applied test potential if the rated output of the test equipment is less than 500VA.

If the rated output of the test equipment is 500VA or more, the applied test potential may be indicated by either:

- 1 - a voltmeter in the primary circuit;
- 2 - a selector switch marked to indicate the test potential; or
- 3 - a marking in a readily visible location to indicate the test potential for test equipment having a single test potential output.

In cases 2 and 3, the test equipment shall include a lamp or other visual means to indicate that the test potential is present at the test equipment output. All test equipment shall be maintained in current calibration.

Products Requiring Dielectric Voltage Withstand Test:

| <u>Product</u> | <u>Test Voltage</u> | <u>Test Time</u> |
|--------------------------------------|---------------------|------------------|
| All products covered by this Report. | 1000Vac | 60 s |
| | or | |
| | 1200Vac | 1 s |

12.0 Revision Summary

The following changes are in compliance with the declaration of Section 8.1:

| Date/ Proj # Site ID | Project Handler/ Reviewer | Section | Item | Description of Change |
|-------------------------|------------------------------|---------|------|-----------------------|
| | | | | None |
| | | | | |
| | | | | |
| | | | | |
| | | | | |
| | | | | |
| | | | | |
| | | | | |
| | | | | |
| | | | | |
| | | | | |
| | | | | |
| | | | | |
| | | | | |
| | | | | |
| | | | | |
| | | | | |
| | | | | |
| | | | | |
| | | | | |
| | | | | |
| | | | | |
| | | | | |
| | | | | |
| | | | | |
| | | | | |
| | | | | |
| | | | | |
| | | | | |
| | | | | |
| | | | | |
| | | | | |
| | | | | |
| | | | | |
| | | | | |
| | | | | |
| | | | | |
| | | | | |
| | | | | |
| | | | | |
| | | | | |
| | | | | |
| | | | | |
| | | | | |
| | | | | |
| | | | | |
| | | | | |
| | | | | |