

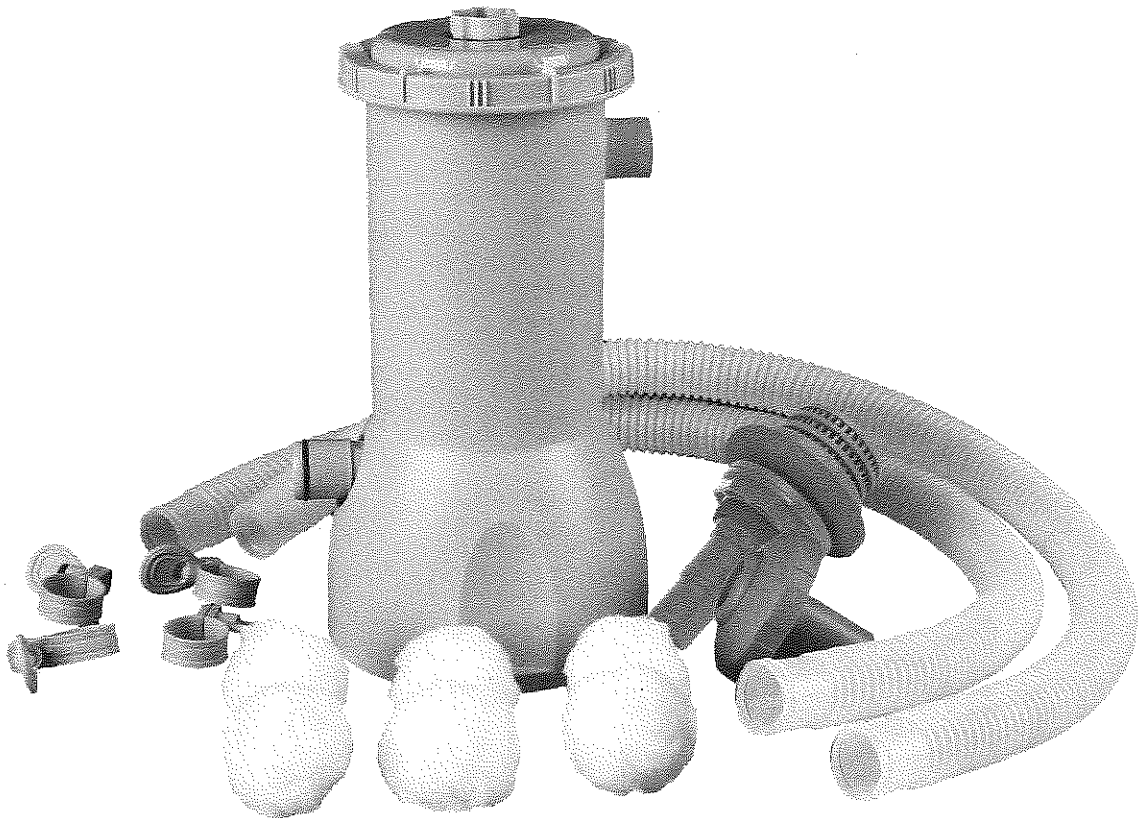

SKU# 230014

# EASY CLEAN 100 CARTRIDGE FILTRATION SYSTEM

## INSTRUCTION MANUAL



# TABLE OF CONTENTS

THANK YOU! .....	3
SAFETY INFORMATION .....	3
SAFETY INSTRUCTIONS .....	4
INSTALLATION INSTRUCTIONS .....	5
ASSEMBLY & INSTALLATION DIAGRAMS .....	6
PARTS LIST & DIAGRAM .....	8
WATER INTAKE & RETURN FITTING INSTALLATION DIAGRAMS .....	9
OPERATION INSTRUCTIONS .....	10
CLEANING & REPLACEMENT .....	10
GENERAL CARE & MAINTENANCE .....	11
90-DAY LIMITED WARRANTY .....	11

# THANK YOU!

Thank you for purchasing this product. We work around the clock and around the globe to ensure that our products maintain the highest possible quality.

Please read the warranty information at the back of these assembly instructions for further details.

## SAFETY INFORMATION

Congratulations, you have purchased a high quality filtration system from Bluebay. This filter system has been manufactured of the highest quality materials and factory tested to ensure years of trouble-free service. To prevent potential injury or unnecessary service calls, please read this entire manual before attempting to assemble, operate, or install the product.

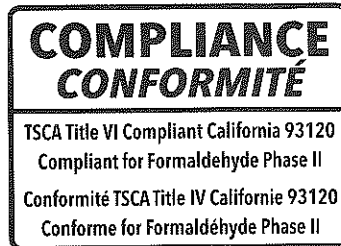
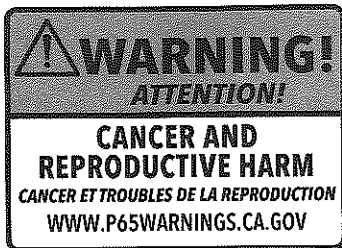

### SAVE THIS INSTRUCTION MANUAL

Use of unauthorized replacement parts voids the warranty

**ATTENTION INSTALLER!** THIS MANUAL CONTAINS IMPORTANT INFORMATION ABOUT THE INSTALLATION, OPERATION, AND SAFE USE OF THIS PUMP AND MUST BE FURNISHED TO THE END USER OF THIS PRODUCT. FAILURE TO READ AND FOLLOW ALL INSTRUCTIONS COULD RESULT IN SERIOUS INJURY.

# 1. SAFETY INSTRUCTIONS

## **WARNING!**

To reduce the risk of injury, do not permit children to use or climb on this product. Closely supervise children at all times. Components such as the filtration system, pumps, and heaters must be positioned to prevent children from using them as a means of access to the pool.

**CAUTION!** This pump is designed for use with storable pools. A storable pool is constructed so that it is capable of being readily disassembled for storage and reassembled to its original integrity. Though this product is designed for outdoor use, it is strongly advised to protect the electrical components from the weather. Select a well-drained area, one that will not flood when it rains. It requires free circulation of air for cooling. Do not install in a damp or unventilated location. If installed within an outer enclosure adequate ventilation and free circulation of air must be provided to prevent overheating of the motor.

**WARNING!** Pool components have a finite life. All components should be inspected frequently and replaced if found to be damaged, broken, cracked, missing, or not securely attached.

### **WARNING! Risk of Electric Shock.**

Hazardous voltage. Can shock, burn, or cause death. To reduce the risk of electric shock, do NOT use an extension cord to connect unit to electric supply. Provide a properly located outlet. It is required that licensed electricians do all electrical wiring. All electrical wiring MUST be in conformance with applicable local and national codes and regulations. Before working on the pump or motor, disconnect motor wiring.

**WARNING!** To reduce the risk of electric shock replace a damaged cord immediately. Do NOT bury cord. Locate cord to prevent accidental damage from lawn mowers, hedge trimmers and other equipment.

**WARNING!** Connect only to a grounding type receptacle protected by a Ground Fault Circuit Interrupter (GFCI).

Contact a licensed electrician if you cannot verify that the receptacle is protected by a GFCI. If there is no GFCI one MUST be installed by a licensed electrician.

**WARNING!** Contact a licensed electrician for information on local electrical codes for bonding requirements.

### **WARNING! Suction Entrapment Hazard.**

Entrapment in suction outlets and/or suction outlet covers, which are damaged, broken, cracked, missing, or unsecured can cause severe injury and/or death due to the following entrapment hazards:

**Hair Entrapment:** Hair can become entangled in the suction outlet cover.

**Limb Entrapment:** A limb inserted into an opening of a suction outlet sump or suction outlet cover that is damaged, broken, cracked, missing, or not securely attached can result in a limb becoming entrapped.

**Body Suction Entrapment:** Pressure applied to a large portion of the body or limbs can result in an entrapment.

**Mechanical Entrapment:** There is potential for jewelry, swimsuits, hair decorations, fingers, toes, or knuckles to be caught in an opening of a suction outlet cover resulting in mechanical entrapment.

## 1. SAFETY INSTRUCTIONS (CONTINUED)

**WARNING!** Failure to install according to defined instructions may result in severe personal injury or death.

**WARNING!** Use of unauthorized replacement parts voids the warranty.

**WARNING!** The maximum head of the pump is 3.7m (12.14-ft). This applies to pumps having a rated power input exceeding 100W. Maximum water temperature: 95°F.

**CAUTION!** Make sure the pump is properly secured and positioned in a dry area before use.

**WARNING!** This pump should not be operated by children or persons with reduced physical, sensory, or mental capabilities or that lack of experience and knowledge of its operation.

**WARNING!** The pump must not be used when people are in the water.

**WARNING!** To prevent possible electric shock, do not attempt to plug in the power cord with wet hands or while standing in water.

**CAUTION!** Make certain that all clamps are tightened and that all hoses are connected properly before starting filtration and before each use of the pump.

**WARNING!** Do not use this filter pump to vacuum pool.

## 2. INSTALLATION INSTRUCTIONS

**\*See Assembly & Installation Diagrams in Section 3 (Page 5-7).\***

1. Set up your pool according to the manufacturer's instructions. Fill it with water according to the instructions in the pool and or skimmer manuals.
  2. Assemble the filter pump per the diagrams in Section 3.
  3. Position the filter pump unit on the outside of the pool at least 7-8 inches below the highest water level in the pool. This is important to maintain the pump's self-priming capability.
  4. **WARNING!** DO NOT PLACE THE FILTER PUMP INSIDE THE POOL.
  5. Position the filter pump at least 24 inches away from the outside of the pool sidewall.
  6. Place the bottom sponge and filter media into the body of the filter pump as shown.
  7. Make certain that the filter chamber rubber gasket is placed in the seal groove on the top of the filter pump.
  8. Screw the filter chamber cover onto the top of the body of filter pump. Tighten by hand only.
- NO TOOLS.**
9. Insert the main body of the water return fitting through the pre-attached tube near the top of the pool wall from the inside of the pool wall. The water return fitting will be sealed when you attach the intake hose and the hose clamp.
  10. Connect the hoses as shown in the installation diagram below. Attach the hoses to the pump and to the wall of pool. Tighten the hose clamps securely with a screwdriver, but do not overtighten and break the hose clamp.
  11. Once the hoses are properly attached you will want to allow the filter pump chamber to fill with water. (See Section 4, #1).

### 3. ASSEMBLY & INSTALLATION DIAGRAMS

1

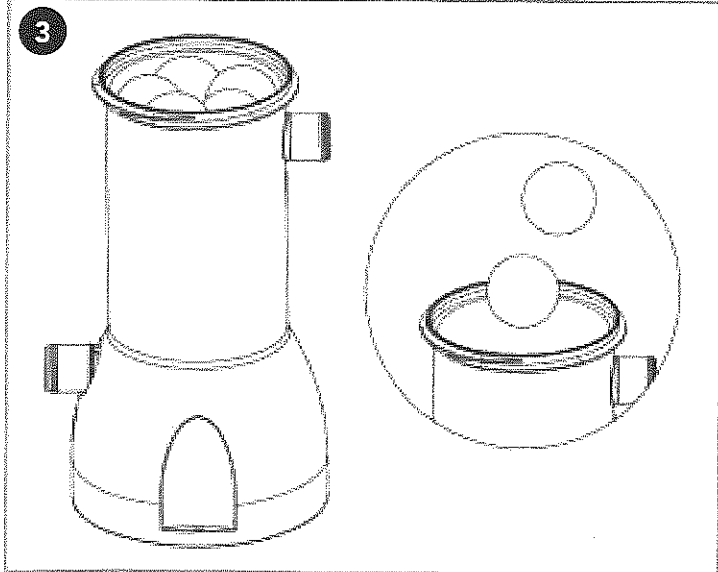
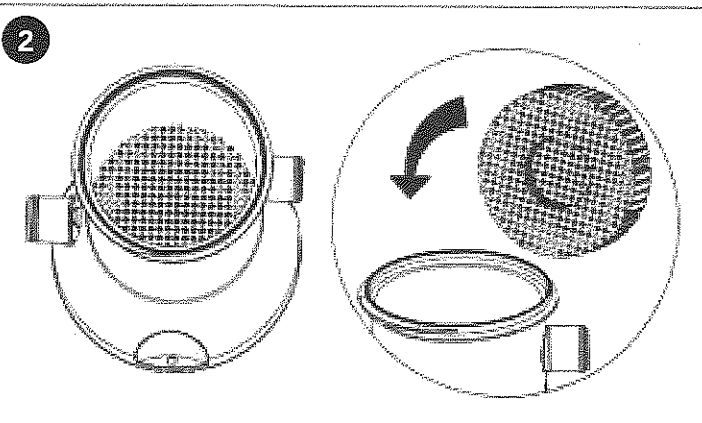
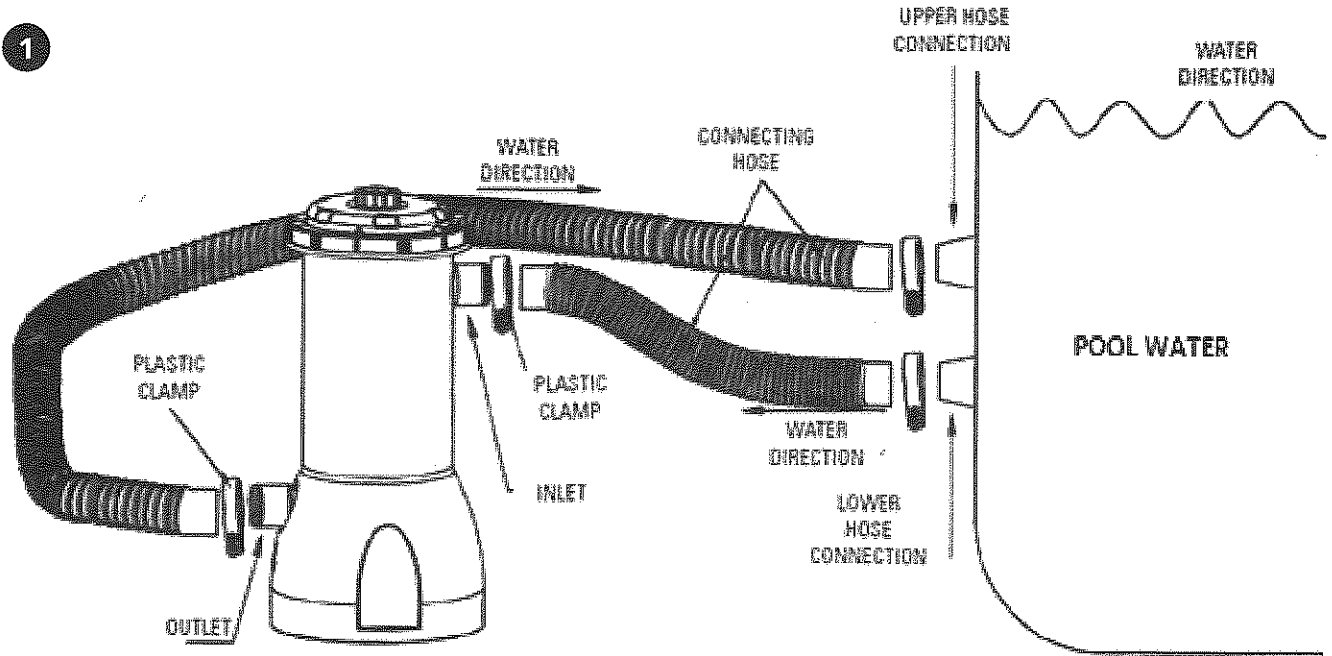

### 3. ASSEMBLY & INSTALLATION DIAGRAMS (CONTINUED)

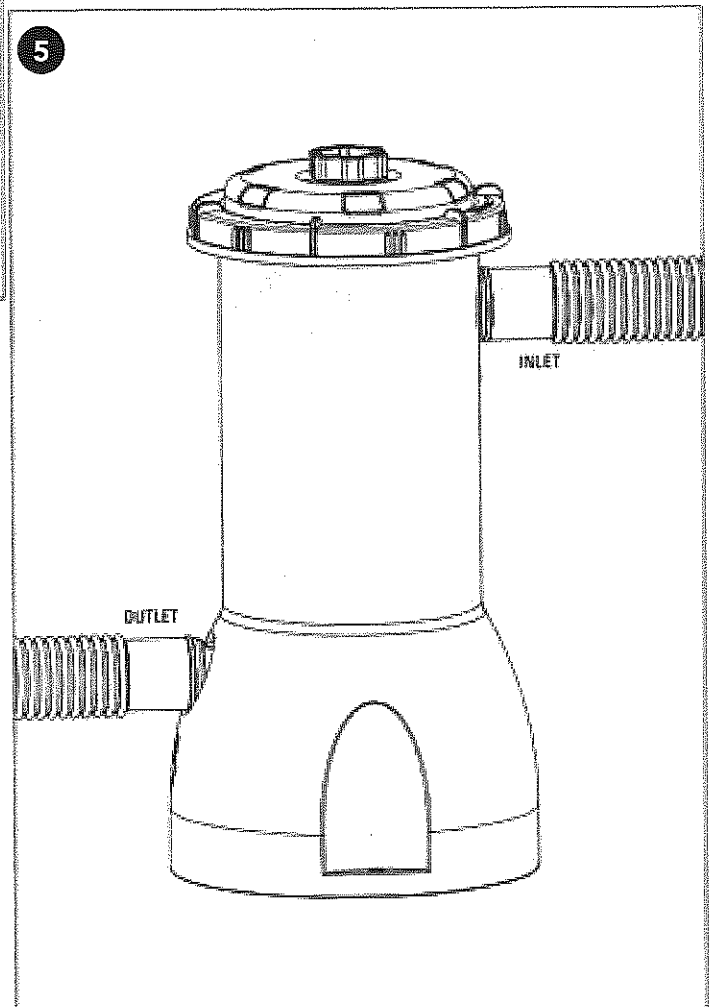
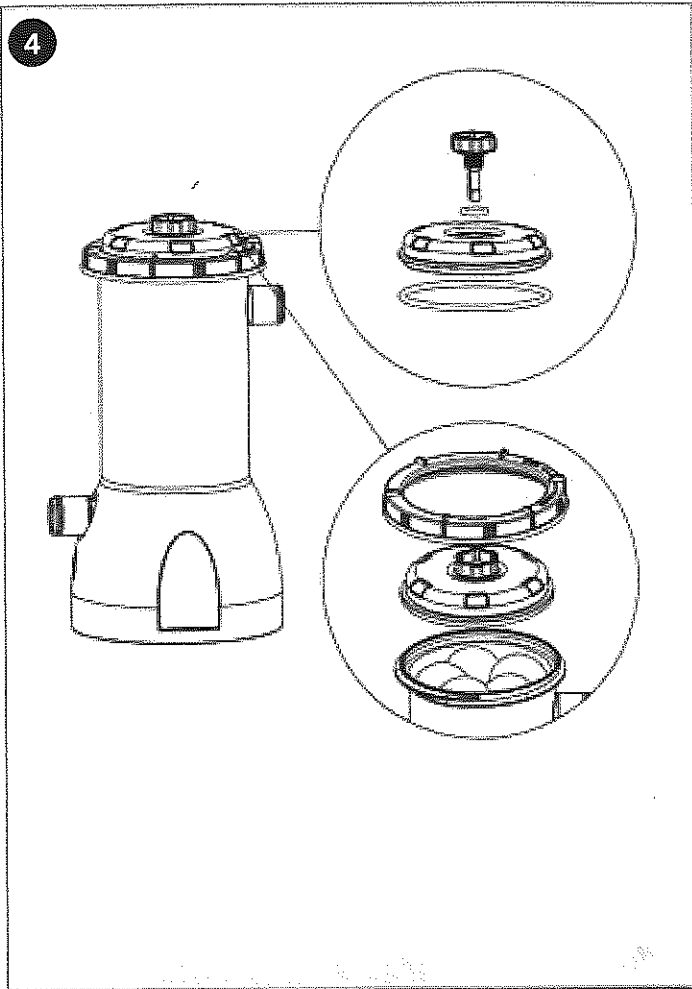

### 3.1 PARTS LIST & DIAGRAM

#### EASY CLEAN 100 FILTER SYSTEM

**NOTE:** This filtration system is also compatible with Type A and Type C cartridges.

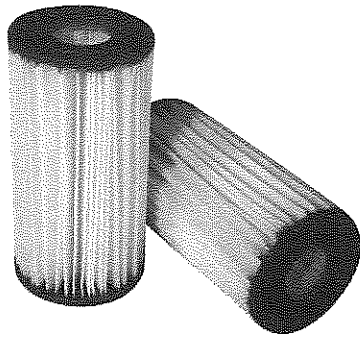

(Diagram 1)

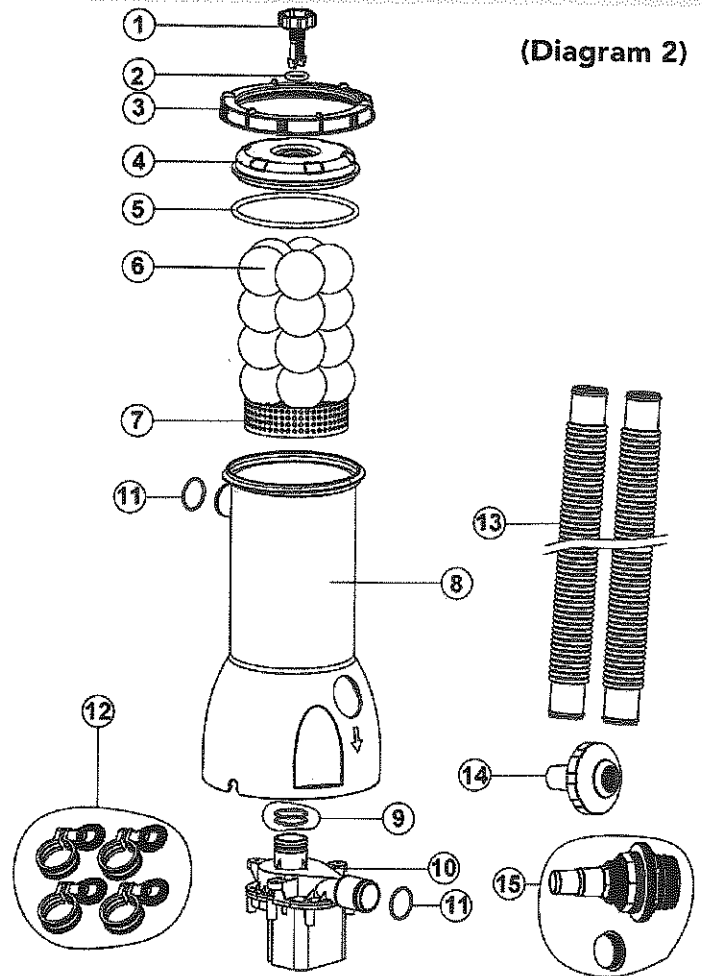

(Diagram 2)

#	Part Description	QTY.	MFG No.	BB No.	For Model #
1	AIR VALVE SCREW	1	ACF180201	NEP20255	230014
2	AIR VALVE O-RING	1	ACF180202	NEP20256	230014
3	PLASTIC NUT	1	ACF180203	NEP20257	230014
4	TOP COVER	1	ACF180204	NEP20258	230014
5	TOP COVER O-RING	1	ACF180205	NEP20259	230014
6	FILTER MEDIA COTTONTAIL BALLS	1	Aqualoon ATX	NE4509	230014
7	FOAM	1	ACF180207	NEP20260	230014
8	BODY	1	ACF180208	NEP20261	230014
9	PUMP O-RING	2	ACF180209	NEP20262	230014
10	PUMP	1	ACF180210	NEP20263	230014
11	SEAL	2	ACF180211	NEP20264	230014
12	PLASTIC CLAMP	4	ACF180212	NEP20265	230014
13	PLASTIC HOSE	2	ACF180213	NEP20266	230014
14	WATER RETURN FITTING KIT 1.25"	1	91194	NBP6160	230014
15	WATER INTAKE FITTING KIT 1.25"/1.5"	1	91195	NBP6159	230014



# 4. WATER INTAKE & RETURN FITTING INSTALLATION DIAGRAMS

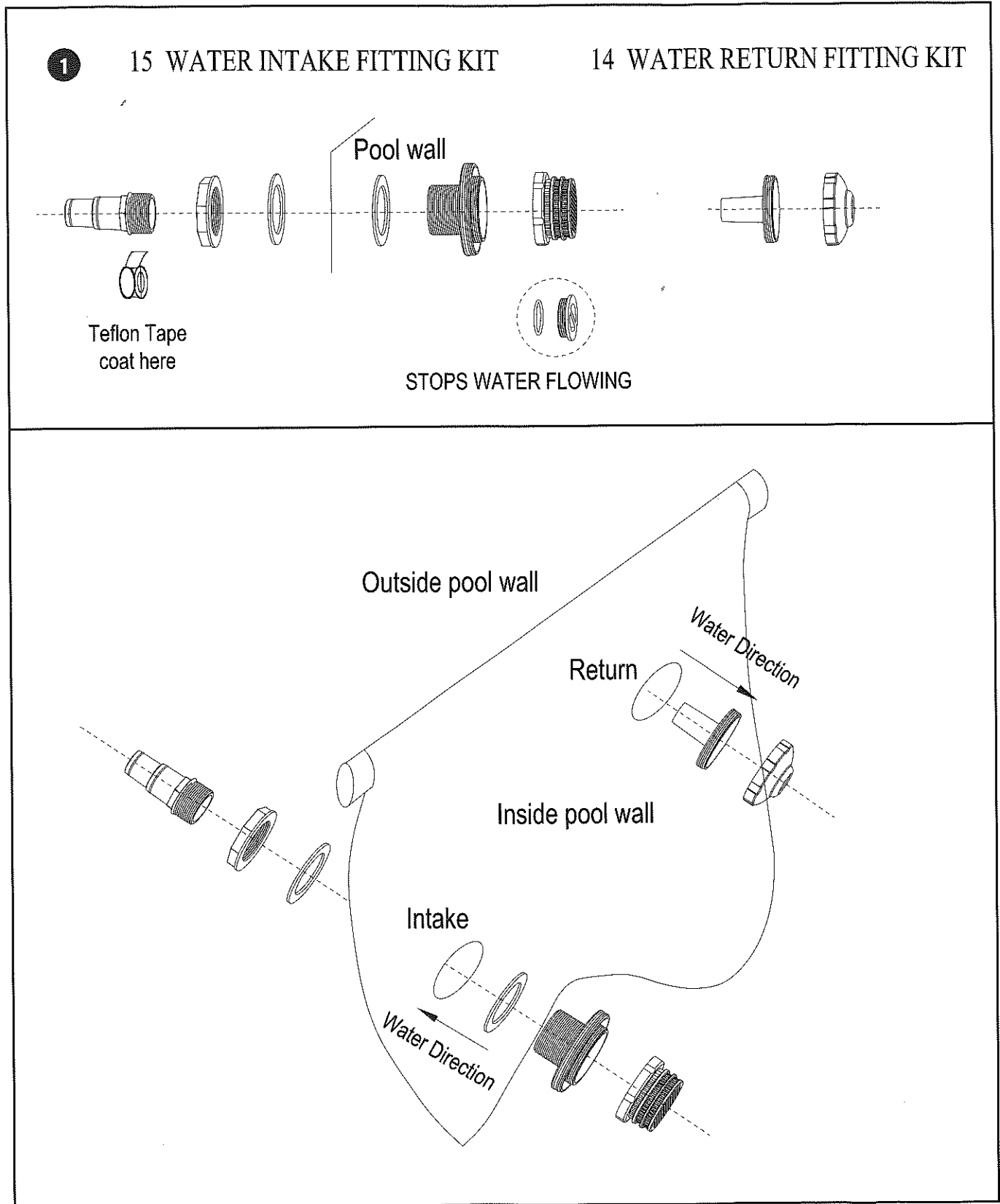

## 5. OPERATION INSTRUCTIONS

1. The filter pump is self-priming as long as it is positioned at least 7 to 8 inches below the highest water level of the lower hose connection. An air relief valve is located on the top of the pump. Turn the valve knob counter-clockwise, allowing air to escape from the tank. When a small amount of water escapes, close immediately. The pump is now completely primed.
2. **CAUTION!** Never operate the filter pump dry. This can cause damage to pump seals resulting in leakage and/or flooding. Dry running damage is not covered by the warranty.
3. Prior to each use, check to ensure that all hose-clamps are tightened.
4. The filter pump must operate in the upright, vertical position.
5. The filter pump must be positioned on level, stable ground.
6. To keep the pool filtered properly, your pump should be run approximately 4 to 6 hours per day. Overuse may cause overheating and/or motor burnout. Use good judgment on extremely hot days.
7. **DO NOT** run the filter pump continuously for an extended period of time.

## 6. CLEANING & REPLACEMENT

1. The filter media in your pump filter system should be inspected and cleaned or replaced when dirty or at least at the start of each new season.
2. Periodical cleaning of your filter media can enhance the effectiveness of your filter pump and prolong the filter media's lifespan prior to replacement.
3. **WARNING!** Always disconnect the power to the unit when cleaning or changing the filter media.
4. Cleaning or changing the filter media:
  - Plug the intake fitting on the side of the pool or if equipped with a shut off valve, close it to prevent water from escaping from the filter tank when you remove the filter canister cover.
  - Turn the air relief screw to release the air suction inside.
  - Remove the filter canister cover and the filter chamber rubber gasket.
  - Remove the dirty filter media and the black foam screen from the filter canister.
  - Rinse dirt and debris from the black foam screen and return to the filter canister.
  - Rinse and clean the filter media or replace with a new filter media and return to the filter canister on top of the black foam screen.
  - Reassemble the filter canister cover, remove the wall plug and open the shut off valve to allow water to enter the filter pump until water comes out of the air relief screw. Then, tighten the air relief screw.
5. Now, reconnect the filter pump to the power supply and resume filtering operation.

## 7. GENERAL CARE & MAINTENANCE

1. To avoid dangerous or fatal electrical shock hazard, always disconnect power to the unit before attempting to clean pump or filter canister.
2. The pump is sealed and requires **NO** mechanical maintenance or lubrication. **DO NOT** attempt to disassemble the pump motor at any time. Doing so will void your warranty.
3. If necessary, clean the outside of the pump with a mild detergent and water.

## 8. 90-DAY LIMITED WARRANTY

This product is warranted to the original purchaser to be free from defects in material or workmanship for a period of ninety (90) days from the date of the original retail purchase.

This warranty does not cover defects or damage due to improper installation, alteration, accident, or any other event beyond the control of the manufacturer. Defects or damage resulting from misuse, abuse, or negligence will void this warranty. This warranty does not cover scratching or damage that may result from normal usage.

This product is not intended for institutional or commercial use; the manufacturer does not assume any liability for such use. Institutional or commercial use will void this warranty.

This warranty is nontransferable and is expressly limited to the repair or replacement of the defective product. During the warranty period, the manufacturer shall repair or replace defective parts at no cost to the purchaser. Shipping charges and insurance are not covered and are the responsibility of the purchaser. Labor charges and related expenses for removal, installation, or replacement of the product or components are not covered under this warranty.

The manufacturer reserves the right to make substitutions to warranty claims if parts are unavailable or obsolete.

The manufacturer shall not be liable for loss of use of the product or other consequential or incidental costs, expenses, or damages incurred by the consumer of any other use. The user assumes all risk of injury resulting from the use of this product.

This warranty is expressly in lieu of all other warranties, expressed or implied, including warranties of merchantability or fitness for use to the extent permitted by Federal or state law. Neither the manufacturer nor any of its representatives assumes any other liability in connection with this product.

**All warranty claims must be made through the retailer where the product was originally purchased. A purchase receipt or other proof of date of purchase will be required to process all warranty claims. The model number and part numbers found within the assembly instructions will be required when submitting any parts requests or warranty claims.**